

# PATTERN INSTRUCTIONS

BERGERE  
DE FRANCE

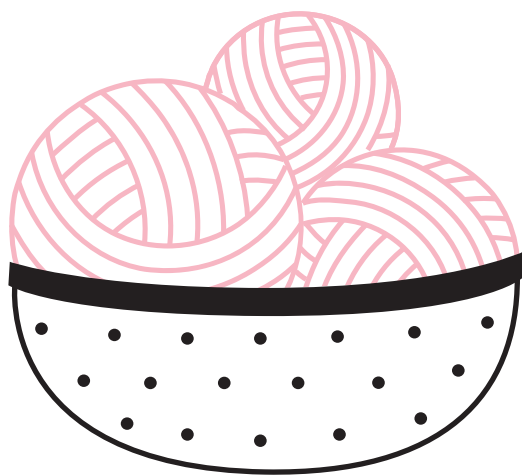

**DON'T PANIC !**

**BERGERE DE FRANCE IS  
ACCOMPANYING ME STEP BY STEP**



### OUR DEDICATED EMAIL

Stuck in the middle of your work? Need a clarification concerning the instructions? Do not hesitate to contact us. An expert knitter will take the time to provide the answers and all the help you need.

[knittingquery@bergeredefrance.com](mailto:knittingquery@bergeredefrance.com)

From Monday to Friday, during office hours



### OUR WEBSITE

[www.bergeredefrance.co.uk/knitting-basics-get-started](http://www.bergeredefrance.co.uk/knitting-basics-get-started)

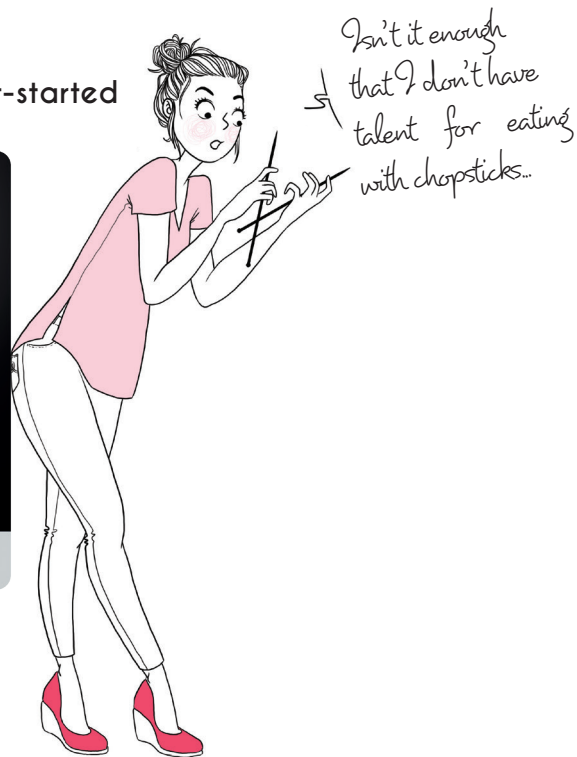
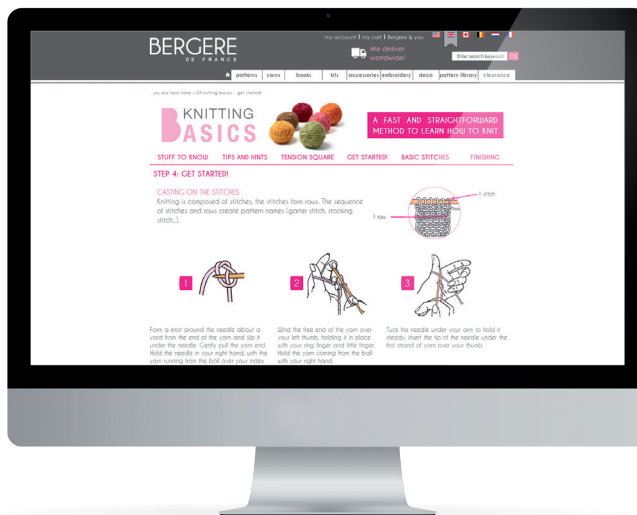

### OUR YOUTUBE CHANNEL

All our video tutorials (in french) are available at :  
[www.youtube.com/bergerefr](http://www.youtube.com/bergerefr)

Stuck in the middle of your work... Need some advice from an expert?



[knittingquery@bergeredefrance.com](mailto:knittingquery@bergeredefrance.com)

From Monday to Friday, during office hours

## CHECK YOUR TENSION

Before you start working on a pattern, make sure that the end-result will be perfect by making a swatch.

**You've got to make sure that your knitting tension is exactly the same as the tension in our pattern. If it isn't, your garment is likely to be too big or too small.**

### HOW TO MAKE A SWATCH ?

Using the yarn, needles, and stitch specified for the pattern, work a square at least 6 in (15 cm) on a side.

Iron the square lightly on the wrong side under a damp cloth or using a steam iron. If the swatch is worked in ribbing, stretch it slightly. With a ruler, count the sts to equal 4 in (10 cm) widthways and 4 in (10 cm) lengthways.

Compare the result with the sample given in our instructions.

*Your tension square matches ours !*

You can start your knitting, you can be sure your project will have the same dimensions as the grid.

*Your sample has more stitches and rows ?*

Your knitting is too tight. Make another swatch with needles one size larger.

*Your sample has fewer stitches and rows ?*

Your knitting is too loose. Make another swatch with needles one size smaller.

When your swatch matches ours, you're ready to follow the instructions.

You can expect to end up with a garment that's just right.

**BEWARE:** It is important to achieve an exact number of stitches for the design to fit correctly. However, the number of rows can be adapted depending on the height indicated in cm.



### Read the instructions

Before you start knitting we advise you to read through the instructions, trying to imagine all of the steps you will be taking. All patterns are well detailed.

The instructions are given for several sizes. We suggest that you circle or underline the numbers that correspond to the size you intend to make. If there's only one number, it applies to all the sizes.

# I LEARN THE BASICS

Knitting is composed of stitches, the stitches form rows. The sequence of stitches and rows create pattern names (garter stitch, stocking st...).

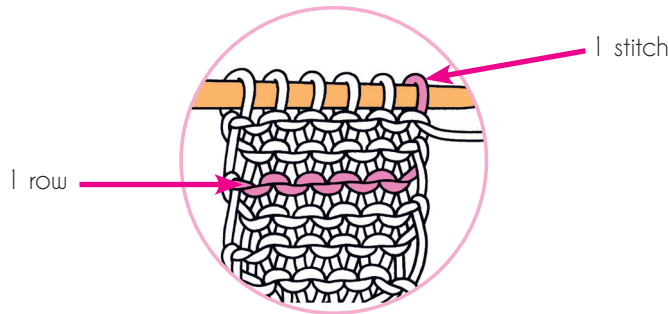

## KNIT

Hold the needle with the cast-on stitches in your left hand with the yarn at the back of the work. Insert the right-hand needle from left to right in the first stitch, passing under the left-hand needle.



Wind the yarn around the right-hand needle passing under and over the tip and hold the yarn against the right-hand needle with your right hand.

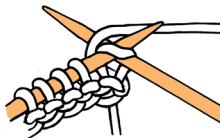

Insert the tip of the right-hand needle into the stitch on the left-hand needle and again over the left-hand needle. The loop thus formed on the right-hand needle is a knit stitch.



Let the loop drop off the left-hand needle and keep the new stitch on the right-hand needle.



To knit a row, repeat steps 1 to 4 until all the stitches have passed from the left to the right-hand needle.

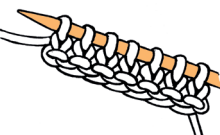

Turn the work, take the needle with the stitches in your left hand, and work the next row.

## PURL

Hold the needle with the cast-on stitches in your left hand with the yarn in front of the work. Insert the right-hand needle from right to left in the first stitch on the left-hand needle.

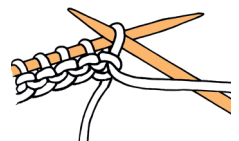

Wind the yarn around the right-hand needle passing over and under the tip and hold the yarn against the right-hand needle with your right hand.



Insert the tip of the right-hand needle into the stitch on the left-hand needle and again under the left-hand needle. The loop thus formed on the right-hand needle is a purl stitch.

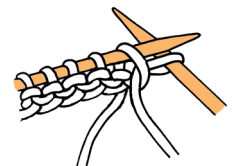

Let the loop drop off the left-hand needle and keep the new stitch on the right-hand needle.



To purl a row, repeat steps 1 to 4 until all the stitches have passed from the left to the right-hand needle.

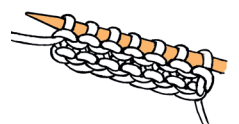

Turn the work, take the needle with the stitches in your left hand, and work the next row.

I DISCOVER  
THE BASIC  
STITCHES

Sorry? What  
was that darling?  
A restaurant?  
Tonight?



GARTER STITCH



When you knit every row, the resulting pattern is called garter stitch.

STOCKING STITCH



Row 1 (right side) : knit.  
Row 2 (wrong side) : purl.  
Repeat these 2 rows.

REVERSE STOCKING STITCH



Row 1 (right side) : purl.  
Row 2 (wrong side) : knit.  
Repeat these 2 rows.



Seeing it live is even easier !  
Find our video tutorials on  
[www.youtube.com/bergerefr](http://www.youtube.com/bergerefr)  
(in french)

# BASIC KNITTING STITCHES

## 1/1 rib

Cast on an uneven number of stitches.

**Row 1 :** knit 1, purl 1, and repeat these 2 stitches to the last stitch, knit 1.

**Row 2 and subsequent rows :** purl over the purl stitches, knit over the knit stitches.

Repeat these 2 rows.

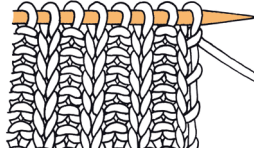

## 2/2 rib

Cast on a multiple of 4 stitches + 2 (e.g., 22 stitches).

**Row 1 :** knit 2, purl 2, and repeat to the last stitches, knit 2.

**Row 2 and subsequent rows :** purl over the purl stitches, knit over the knit stitches.

Repeat these 2 rows.

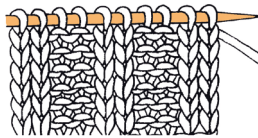

## Seed or moss stitch

Cast on an uneven number of stitches.

**Row 1 :** knit 1, purl 1, repeat these 2 stitches.

**Row 2 and subsequent rows :** purl over knit stitches, knit over purl stitches.

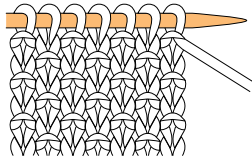

## Corn stitch

Cast on an uneven number of stitches.

**Row 1 :** knit 1, purl 1, repeat these 2 stitches, ending with knit 1.

**Row 2 :** purl over purl stitches, knit over knit stitches.

**Row 3 :** purl over knit stitches, knit over purl stitches.

**Row 4 :** purl over purl stitches, knit over knit stitches.

Repeat these 4 rows.

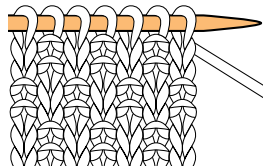

## Yarn forward

By bringing the yarn forward you add a stitch and make an eyelet.

Bring the yarn in front of the work then over the right-hand needle.

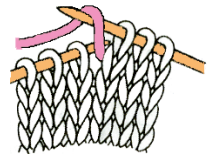

Work the next stitch on the left-hand needle. The yarn forward loop forms an extra stitch with a hold at its base on the right-hand needle.

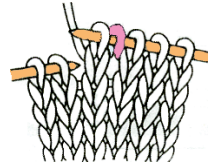

**Next row :** When you come to the yarn forward loop, purl it as you would any other stitch; you now have 1 extra stitch.

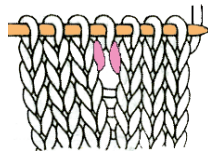

## Knit 2 together

Put the right needle through the 2nd then the 1st stitch on the left hand needle.

Knit the 2 stitches together (wrap yarn around right hand needle and pull through the 2 stitches on the left needle).

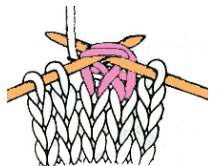
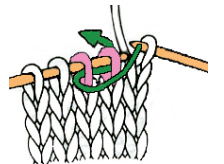

By knitting 2 stitches together you will have 1 less stitch on the needle..

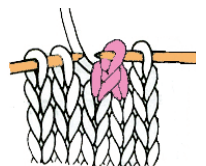

## Slipped stitch

With the yarn at the back of the work, insert the right-hand needle into the next stitch from right to left, as if to purl. Slip the stitch on to the right-hand needle and continue working as given.

**Next row :** Purl the slipped stitch.

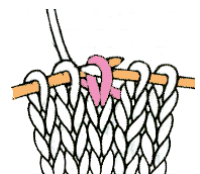

## Single decrease

Slip a stitch on to the right-hand needle as if to knit.  
Knit the next stitch.

Using the left-hand needle, pass the slipped stitch over the stitch you just worked.

After working a single decrease, you have 1 less stitch on the needle.



## Double decrease

Slip a stitch on to the right-hand needle as if to knit.  
Knit the next 2 stitches together.

Using the left-hand needle, pass the slipped stitch over the 2 stitches you just worked.

After working a double decrease, you have 2 fewer stitches on the needle.

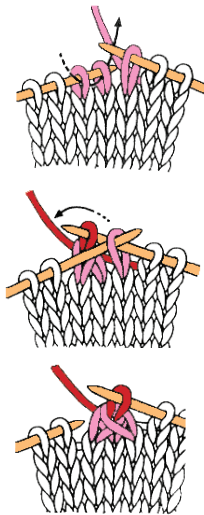

## Twisted knit stitch

Knit the stitch, inserting the needle through the back loop to twist the new stitch.

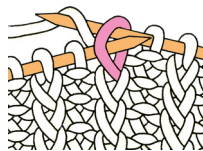

## Twisted purl stitch

Purl the stitch, inserting the needle under the back loops to twist the new stitch.

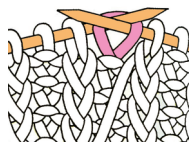

## Nonstitch or suppressed stitch

Sometimes, the number of stitches varies from row to row in a pattern; the nonstitches or suppressed stitches are represented by black squares on the chart. When you follow the chart, do not try to work the black squares but go directly to the next square.

## Working in reverse

When instructed on the front of a garment, for example a jacket, to work the other front in reverse. If you increased or decreased at the beginning of a right side row on the first front you must increase or decrease at the end of the right side row on the second front at the same measurement. The positions of the stitches used will also be reversed, if you ended with a ribbed section for a border on the first front you will start with the ribbed section on the second front. However the pattern should remain the same (do not reverse a cable twist for example).

## Double decrease slip slip knit

Slip 2 stitches as if to knit. Knit 1.  
Pass the 2 slipped stitches over the stitch just worked..

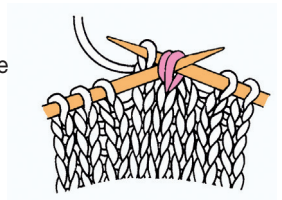

## Raglan decreases

This method of decreasing is always used for Raglan sleeves. It forms a line of slanting stitches parallel with the seam. The decrease is worked with the right side facing, one or more stitches from the edge.

The example shows decreases 1 stitch from the edge :

At beginning of row, with right side facing, knit 1, slip 1, knit 1, pass slipped stitch over (See above).

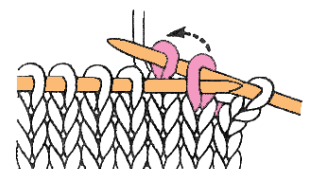

Continue the row as indicated. When 3 sts are left on the left-hand needle, knit the next 2 sts together (see knit 2 together, page 7), knit the last stitch.

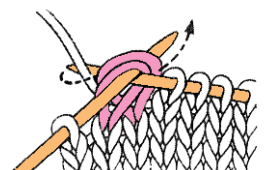

## Increases within a row

When you need to increase a stitch in a row you will need to work twice into one stitch.

Put your right needle through the loop of the stitch below the current stitch on your left needle, knit into this stitch.

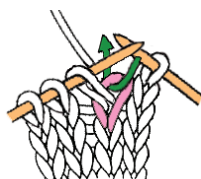

Work the stitch on your left needle as normal.

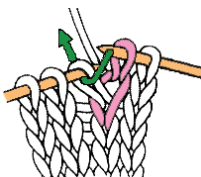

You will have one more stitch.

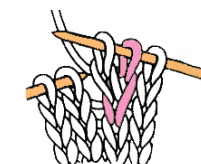

## Increases 1 stitch in from edge of row

These increases are always done on the right side of work, 1 stitch in from the edge.

At the beginning of the row, on the right side of work, knit 1 stitch, put the right needle under the horizontal thread before the first stitch on left needle.



Put this strand onto the left needle.

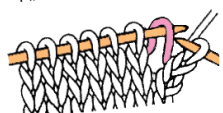

Knit into the back of this loop to twist it.

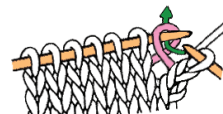

This prevents a gap forming at the bottom of the increased stitch. Continue along the row.

At the end of the row, on the right side of work, work until 1 stitch remains on left needle, pass right needle through the back of the horizontal thread between stitches and place on left needle.

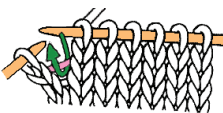

Knit this stitch as normal then knit last stitch.

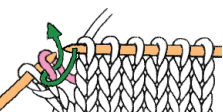

## Increases of one stitch or more at end of work

Wrap yarn around the needle at the beginning of the row as many times as you need stitches. If you are increasing at each end you will also need to do at the end of the row.

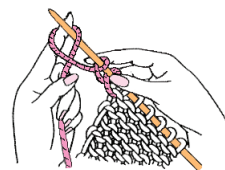

Work these stitches as knit or purl in the pattern required.

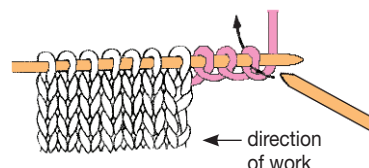

## Stretch cast-on

**Short Row Shaping** Short rows are rows which are not worked in their entirety, this gives a curve to the work as more rows are completed on one side than the other. They can be used on just one side of work or both sides, creating a gentle slope instead of the stepped edge created by casting off a series of stitches.

When told to turn the work during the progress of a row you will not work the remaining stitches on the left hand needle.

To avoid creating a hole when you turn the work, after turning, with the yarn at the front of work (as if about to purl), slip the 1st stitch on the left hand needle onto the right hand needle as if to purl, then take yarn back to back of work (called a wrap) & work the remaining stitches as normal.

When you have finished the short row shaping and need to knit across the whole row you need to knit together the wrap & the next stitch. Take the wrapped stitch back over the top of next stitch then knit both together.

## Stretch cast-on

Take a ball of yarn in a contrasting colour and cast on half the required number of stitches plus 1 extra.

For example : If the pattern tells you to cast on 45 stitches, using the contrasting yarn cast on  $\frac{45 + 1}{2} = 23$  stitches.

Now, using the yarn you intend to work the pattern with, work as follows :

**Row 1 :** \* knit 1, bring yarn forward under the needle, yarn over \*. Repeat from \* to \*. End with knit 1.

**Row 2 :** Slip the first stitch as if to purl on to the right-hand needle, \*pass yarn to back, knit 1 (= yarn forward loop from previous row), bring yarn forward, slip next stitch as if to purl \*. Repeat from \* to \*.

**Row 3 :** \* knit 1, yarn forward, slip 1 stitch as if to purl, pass yarn to back \*. Repeat from \* to \*. End with knit 1. Continue working in 1/1 rib, beginning Row 1 with purl 1. After completing the ribbing, pull out the contrasting yarn.

## Casting off stitches

### 1) To form armholes or collar

You must cast off stitches at the beginning of rows:

On the right side of work, slip 1 stitch onto the right needle as if to purl. Knit the following stitch.

Using the left needle pass the slipped stitch over the top of the 2nd stitch on the right hand needle. You have cast off 1 stitch.

Knit the next stitch and pass stitch on right needle over the top, you have cast off a 2nd stitch. Repeat this step for the required number of stitches. On the following row, on the wrong side of work, cast off in the same way but work the stitches as purl stitches.

On the following row, cast off the next number of stitches indicated in the pattern to obtain a sloped edge.

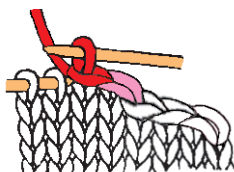
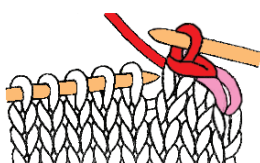
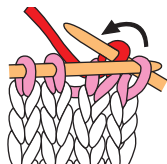
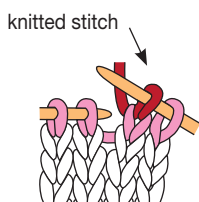

### 2) When work is complete, to cast off all stitches.

Start to cast off as for casting off at the beginning of row: Slip the 1st stitch, knit the following stitch. With the left needle, pass the slipped stitch over the top of the knitted stitch.

Knit the next stitch and with the left needle, pass the 1st stitch on needle over the top of the current stitch. One stitch remains on right needle.

Repeat this sequence until all stitches from the left needle have been worked and only one stitch remains on right needle. Cut thread 10 cm from work and pull through remaining stitch using needle.

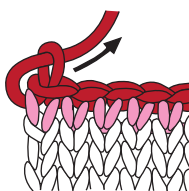
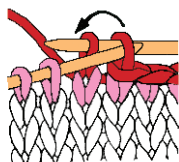

## Small buttonholes

For a small buttonhole, one stitch is sufficient to make a buttonhole:

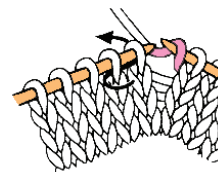

Yarn over needle, then knit 2 together. On the next row work the yarn over needle as normal.

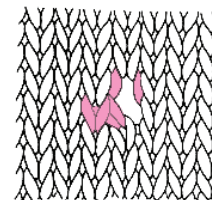

## Buttonholes

**1st row :** Work to where the buttonhole should be, cast off the number of sts indicated in the pattern and work to end of row.

**2nd row :** Work to cast off sts, cast on the same number of sts as 1st row and work to end of row.

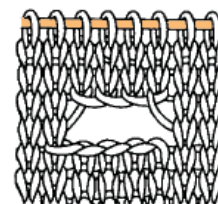

## No-cut buttonholes

Using a sewing needle, pick up the horizontal strand of the stitch where you want to place the buttonhole, pull it up and attach it 2 rows higher with a few little stitches on the wrong side of the work. Repeat with the horizontal strand below the first strand, and attach it in the same way 2 rows down.

## Pattern stitches

Instructions for pattern stitches are always given row by row, as well as in chart form, with each square on the chart representing 1 stitch and 1 row.

The accompanying legend explains the terms and matches the symbols to the stitches. The chart shows the right side of the work, it is not always possible, however, to include all the subtleties of a pattern stitch in a chart. For that reason, we advise you to always read the row-by-row instructions, even if you prefer to use a chart.

Knit over knit and purl over purl is an instruction often used for ribbing and pattern stitches.

## Cables

It is easy to work narrow cables over 2 stitches :

**Right cross 2 :** Passing in front of the work, knit the 2nd st on the left-hand needle then knit the first stitch; slip both stitches on to the right-hand needle at once.

**Left cross 2 :** Passing behind the work, knit the 2nd st on the left-hand needle then knit the first stitch as usual; slip both stitches on to the right-hand needle at once.

A cable made up of 3 or more stitches requires the use of a cable needle.

### Cable 4 left (front) :

Slip 2 stitches on to a cable needle in front of work, knit 2, then slip the 2 stitches from the cable needle on to the left-hand needle and knit 2.

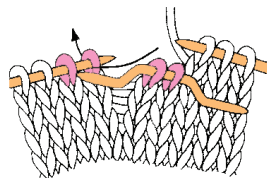

### Cable 4 right (back) :

Slip 2 stitches on to a cable needle at back of work, knit 2, then slip the 2 stitches from the cable needle on to the left-hand needle and knit 2.

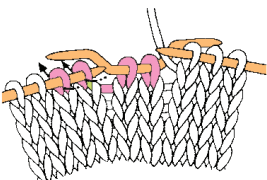

## Picking up stitches

When the different sections of the garment are completed, you may need to pick up stitches at the edge of your work, for example on the collar or front borders

To pick up the stitches knit wise, put needle through the middle of each stitch on the last row and pick up the loop. When you are picking up stitches on rows where there are more rows than stitches required work through 2 or 3 rows then skip 1 row to obtain the number of stitches required in the pattern.

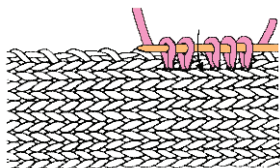
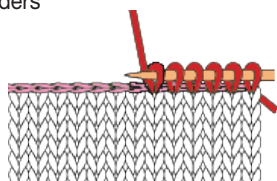

## Backstitched seam

Place the 2 pieces right sides together. Thread a tapestry needle with the matching yarn, insert the needle through both thicknesses, matching stitch for stitch, and bring the needle out 2 rows further along.

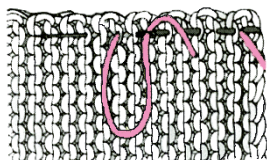

## Grafting

This technique is widely used in European patterns, but is not so popular among UK and US knitters. When you have completed the sections, do not cast off, but leave the stitches on a spare needle.

Thread a tapestry needle with the matching yarn. Work with right side facing. Place the 2 spare needles together.

Insert the tapestry needle through the centre of the first stitch on the front needle as if to purl (leave the stitch on the needle),

– and bring the tapestry needle out at the centre of the first stitch on the back needle as if to knit (leave the stitch on the needle),

\*bring the tapestry needle through the centre of the first stitch on the front needle again as if to knit and slip off the stitch,

– Insert the tapestry needle through the centre of the next stitch on the front needle as if to purl (leave the stitch on the needle),

– bring the tapestry needle out at the center of the next (first) stitch on the back needle again as if to purl and slip off the stitch,

– Insert the tapestry needle through the centre of the next stitch on the back needle as if to knit (leave the stitch on the needle)\*, maintaining an even tension. Repeat the movement until the seam is complete.

Work all the free stitches into the seam one by one and let the stitches drop off the spare needles as they are grafted together.

The finished seam will look identical to a row of knitting.

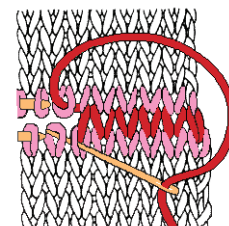
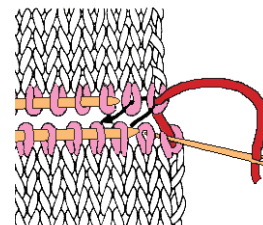

## Invisible seam

Following the sketch, working with the 2 pieces to be joined, pick up the horizontal thread between the first and second stitches and pull firmly to bring the edges together and make the join invisible. If the edge is very uneven, work the thread between the second and third stitches.

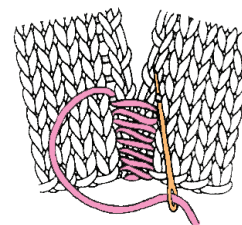

You may also use an invisible seam to join at the shoulder. In that case, pick up the 2 upright strands of a stitch 1 row in from the edge.

## Fair Isle

Fair Isle and contrasting colour patterns.

These patterns are worked in stocking stitch using several colours to make a design shown on a chart.]

Each square on the chart represents 1 stitch and 1 row. A legend accompanying the chart indicates the colours. Read the chart beginning at the bottom row, from right to left for the right side of the work, and from left to right for the wrong side rows.

### KNITTED PATTERNS

Various techniques are used according to the complexity of the pattern.

- When the motifs of the design are small and close together, you may let the yarn not in use run loosely at the back of the work. Make sure that you don't pull the yarn taut or it will pucker the pattern.
- When the motifs are far apart or very wide, pass the yarn not in use behind the work attaching it along with the one that is in use : hold the yarn not in use in your left hand, then work a stitch passing the right-hand needle under that yarn but taking care not to actually knit the yarn. Repeat this movement every other stitch.
- When the motifs are very large or use several colours, do not try to pass the yarn at the back of the work. Instead, use several balls of each colour, as needed, using the intarsia technique. Each time you change yarn colour, make sure that you twist the yarns loosely at the back of the work to avoid forming holes in the texture.

In all three cases, take care to work evenly, especially where the colours change and stitches tend to be loose.

### EMBROIDERED PATTERNS

Embroidery can be used to advantage instead of knitted patterns when the motifs are made up of relatively few stitches.

This technique avoids the problems of disposing of extra yarns at the back of the work. For embroidery, form open chain stitch with a tapestry needle, working from right to left.

Bring the needle from wrong side to right side at the base of the first stitch, insert the needle from right to left under both strands of the stitch above the one being worked (see sketch no. 1), then insert the needle again at the base of the stitch being worked and bring it out at the base of the next stitch (see sketch no. 2).

Use this technique to embroider the number of stitches indicated. After the last stitch, bring the needle out at the base of the row above. Turn the work to start again from right to left.

Sketch no 1

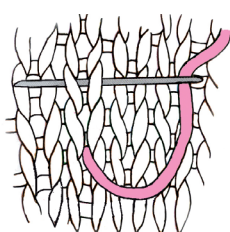

Sketch no 2

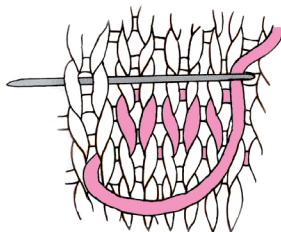

## Grafting a border

When the border is finished, work a few rows of stocking stitch using a contrasting yarn.

Take the work off the needle and press the stocking stitch section with a warm iron under a damp cloth to prevent it from unraveling. Pin the border to the finished garment, matching the stitches. Unravel all but the last row of stocking stitch. Now graft the stitches, waving the tapestry needle in and out, and unravel the last row of stocking stitch as you go. Bring the needle from back to front through the centre of the second stitch, work a back stitch into the first stitch and bring the needle out again at the centre of the third stitch; now work a backstitch again into the second stitch and continue thus with backstitching as far as the last stitch.

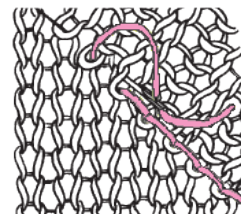

## Chainstitch shoulder seam

### CHAINSTITCH SHOULDER SEAMS

or 3 needles cast off or 3 needles bind off

Leave the remaining shoulder stitches on a spare needles. Place back and front with wrong sides together.

Using a third needle, knit together the first stitch from the front needle with the first from the back needle, and repeat with the second stitch from each needle. You now have 2 stitches on the right-hand needle.

Pass the first stitch over the second, as in casting off. Continue thus until you have cast off all the shoulder stitches. The result is a chain that shows on the right side and a shoulder seam that will not go out of shape. To obtain an invisible seam on the right side, place back and front with right sides together.



# BASIC CROCHET STITCHES

## Chain stitch (ch or ch st)

The first stitch in crochet. Make a loop. Insert the hook in the loop. \* Pass the hook under the yarn for a yarn over (yo), and pull the yo through the loop = 1 ch st. Rep from \* to work as many ch sts as needed.

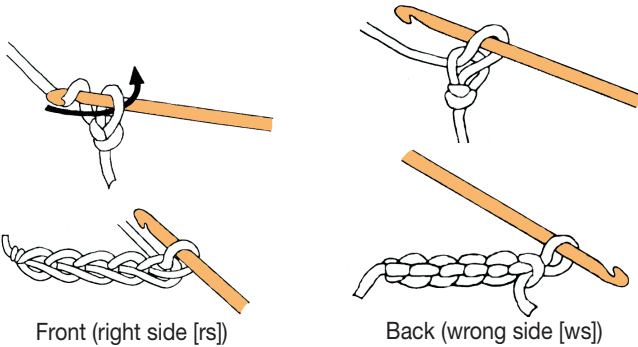

## Slit stitch (sl st)

Insert the hook into a stitch, yo and pull through the loop on the hook in a single movement.

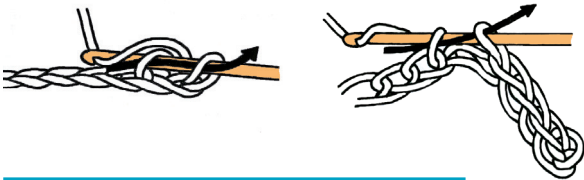

## Single Crochet (

UK: Double Crochet) = sc (uk: dc)

Insert the hook into a stitch, yo and draw up loop, yo and through both loops on hook.

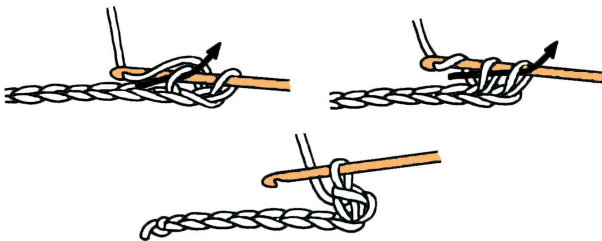

## Crab Stitch (sc (uk: dc) worked from left to right)

Beg at left edge: \* insert hook into a stitch, yo and draw up lp, yo and through both lps on hook \*, rep from \* to \*, inserting hook into preceding st..

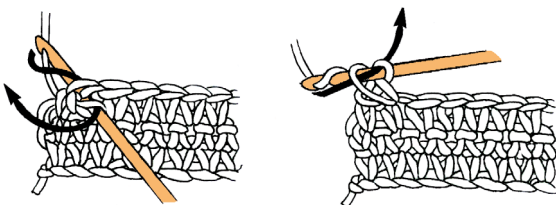

## Half Double Crochet

(UK: Half Treble) = hdc (uk: half tr)

Yo, insert the hook into a stitch, yo and draw up loop, yo and through all 3 loops.

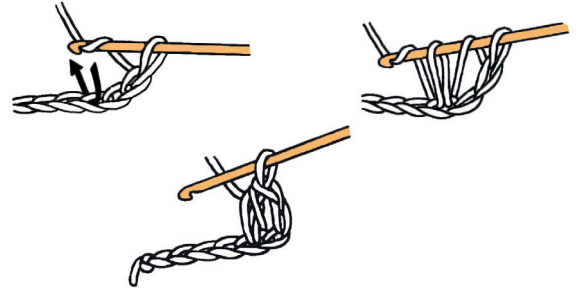

## Double Crochet

(UK: Treble) = dc (uk: tr)

Yo, insert the hook into a st, yo and draw up loop, yo and through first 2 loops on hook, yo and through remaining 2 loops.

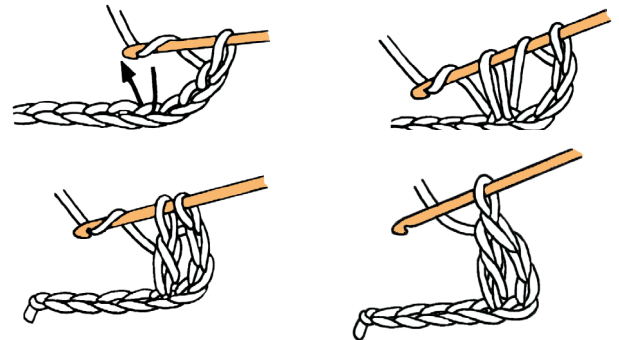

## Treble (UK: Double Treble)

= tr (uk: dbl tr)

Yo twice, insert the hook into a stitch, yo and draw up loop, yo and through first 2 loops on hook, yo and through 2 loops on hook, yo and through remaining 2 loops.

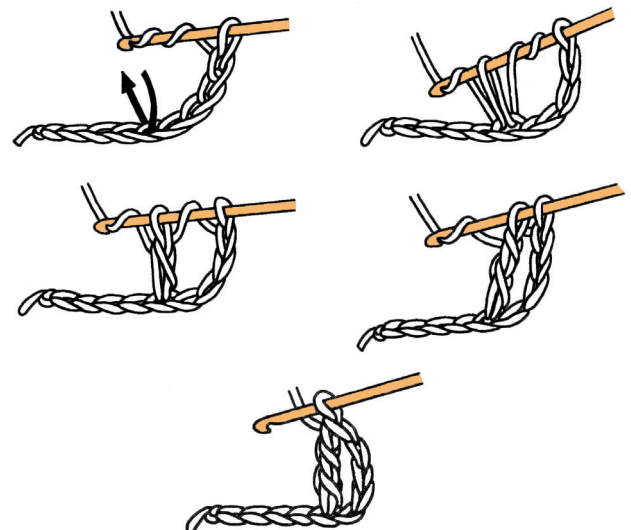

## Double Treble

(UK: Triple Treble) = dbl tr (uk: tr tr)

Yo 3 times, insert the hook in a stitch, yo and draw up loop, yo and through first 2 loops on hook, yo and through 2 loops on hook, yo and through 2 loops on hook, yo and through remaining 2 loops.

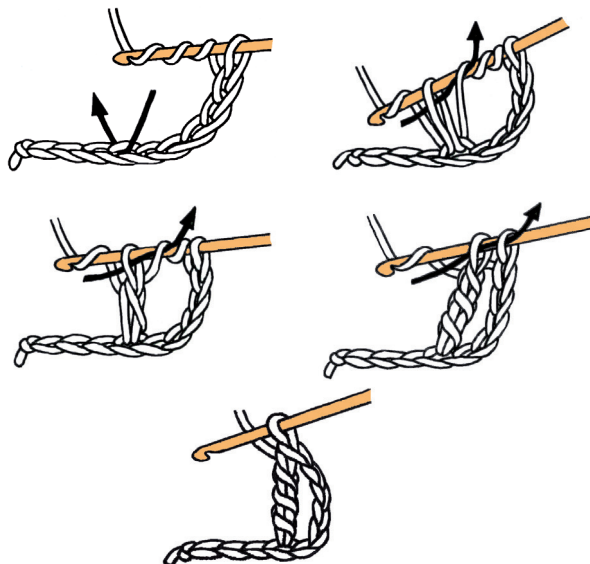

## Beginning with a round

Wind the yarn around the tip of your index finger, slip the hook through the loop, yo and draw up lp, yo and through the loop as shown, then work as many dc as indicated. To end the first round, work a sl st over the first dc and pull gently but firmly on the end of yarn to close up the initial ring..

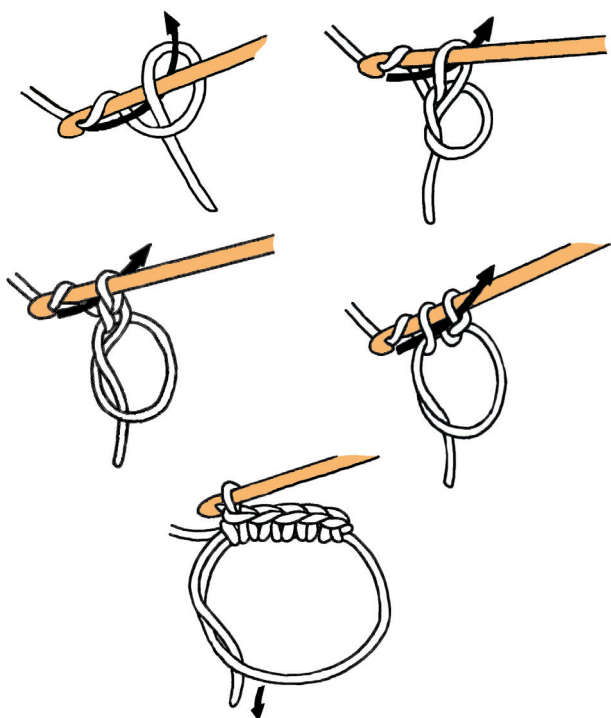

## 2 Single Crochet Together (UK: 2 Double Crochet Together) = 2 sc tog (uk: 2 dc tog)

Leaving last loop of each st on the hook, work incomplete sc as follows: Insert hook into a st, yo and draw up loop, insert hook into next st, yo and draw up loop, yo and through all remaining 3 loops.

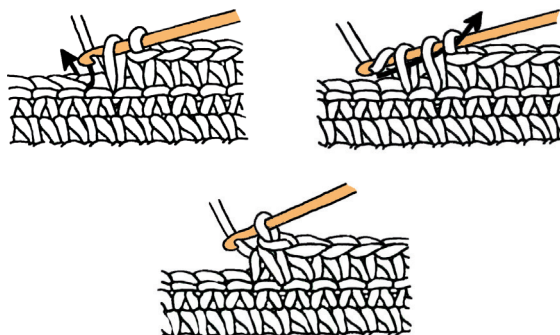

## 3 single crochets together (3 sc tog) [3 double crochets together : 3 dc tog (UK)]

Leaving last loop of each stitch on the hook, work incomplete sc as follows; insert hook in a stitch, yo and draw up loop, insert hook in next stitch, yo and draw up loop, insert hook in next stitch, yo and draw up loop, yo and through all remaining 4 loops at once.

## 2 Double Crochets Together

(UK: 2 Trebles Together) = 2 dc tog (uk: 2 tr tog)

Leaving last loop of each st on the hook, work incomplete dc as follows : yo, insert the hook into a st, yo and draw up loop, yo and through first 2 loops on hook, yo, insert hook into next st, yo and draw up loop, yo and through first 2 loops, yo \* and through all 3 remaining loops.



## 3 Double Crochets Together (UK: 3 Trebles Together) = 3 dc tog (uk: 3 tr tog)

As for 2 dc tog as far as \*, then insert hook into next st, yo and draw up loop, yo and through 2 loops on hook, yo and through all 4 remaining loops.

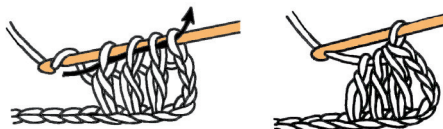

## 2 or 3 Double Crochets Together (UK: 2 or 3 Trebles Together) = 2 or 3 dc tog (uk: 2 or 3)

As for dc tog (tr tog), but beg by working yo twice.

# EMBROIDERY STITCHES

Stem stitch

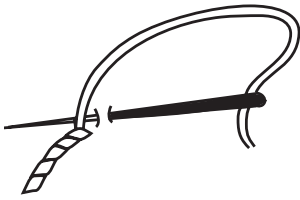

Backstitch



Bullion stitch

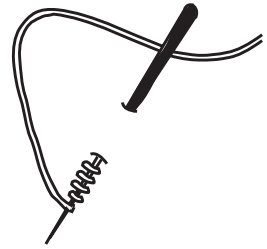

Running stitch

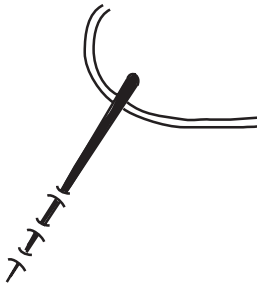

Chain stitch

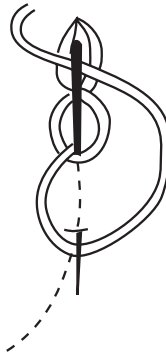

Straight stitch

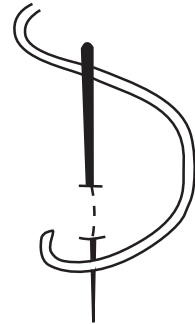

Blanket stitch

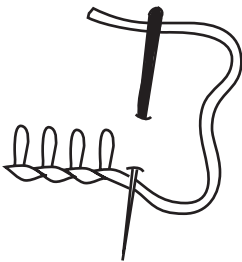

Feather stitch



French knot

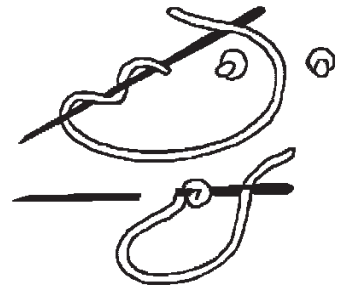

Lazy daisy stitch

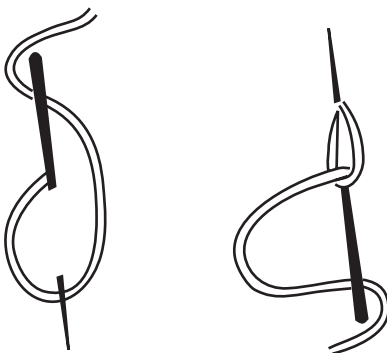

Cross stitch

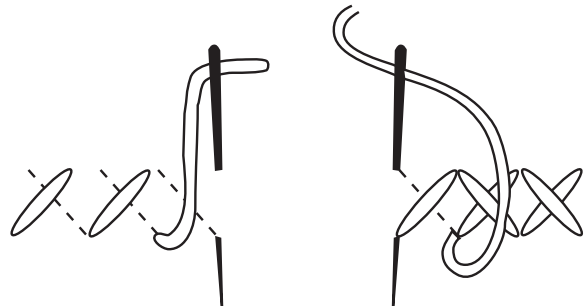



# SWEATER WITH CENTRAL CABLE



Quality:  
**LUMIS & ANGEL 50**

Needles :  
**5.0 & 6.0 mm**  
**1 cable needle (cn)**

Sizes		S	M	L	XL	XXL
Quality LUMIS		Number of bobbins				
Blanc	54754	11	12	13	15	16
Quality ANGEL 50		Number of balls				
Blanc cassé	53070	2	3	3	3	3

## ● Abbreviations

**Cross Left** = CL

**Cross Right** = CR

**6CL**: Slip 3 sts onto a cn at front of work, k3, then k3 from cn.

**6CR**: Slip 3 sts onto a cn at back of work, k3, then k3 from cn.

**3CR2P**: Slip 2 sts onto a cn at back of work, k3, then p2 from cn.

**3CL2P**: Slip 3 sts onto a cn at front of work, work the next st & the yo p-wise, then k3 from cn.

**3CR p1tbl & p1**: Slip the next yo & foll st onto a cn at back of work, k3, then work the sts from cn as foll: p1tbl into the yo & purl the last st.

## ● Stitches used

The sweater is made using 1 strand of LUMIS & 1 strand of ANGEL 50 throughout. Wind the balls together before use to obtain an even yarn.

**2/2 RIB**, using 5.0 mm needles.

**PATTERN ST**, using 6.0 mm needles. Over an odd number of sts.

**Row 1 (RS)**: p1, \*k1 tbl, p1\*, rep from \* to \*.

**Row 2**: knit.

Rep these 2 rows.

**STOCKING ST (St st)**, using 6.0 mm needles.

**CABLE PATT**, using 6.0 mm needles. Over 34 sts. Foll the Chart.

## ● Tension/Gauge

To achieve a good result it is essential to make a tension square (see "Check Your Tension" instructions at beginning of book).

17.5 sts & 24 rows over Patt st using 6.0 mm needles = 10 cm (4 in) square.

34 sts Cable patt = 12 cm (4 ¾ in) wide.

## ● To make

### BACK:

Using 5.0 mm needles & a ball of 2 strands of yarn together CO **82-90-98-106-114** sts.

**Row 1 (RS)**: \*k2, p2\*, rep from \* to \* ending with k2.

**Row 2**: \*p2, k2\*, rep from \* to \* ending with p2.

These two rows form 2/2 rib, rep until work measures **5 cm (2 in) [14 rows]** total, **but** on the final row **for sizes S & XXL** inc 1 st, **for sizes M-L & XL** dec 1 st (= **83-89-97-105-115** sts).

Change to 6.0 mm needles & cont in Patt st until work measures **32-33-33-34-35 cm (12½-13-13-13¼-13¾ in) [80-82-82-84-86 rows]** total.

**Next row (RS)**: k4-4-5-5-6, work in Patt st until 4-4-5-5-6 st rem on LH needle, k4-4-5-5-6.

**Next row (WS)**: p4-4-5-5-6, work in Patt st until 4-4-5-5-6 st rem on LH needle, p4-4-5-5-6.

Cont in patt as est with St st at the edges and rem in Patt st until work measures **33-34-34-35-36 cm (12½-13¼-13¼-13¾-14 in) [82-84-84-86-88 rows]** total.

### Raglan

Cast off **2-2-3-3-4** sts at beg of next 2 rows. **79-85-91-99-107** sts rem.

**Next row (RS – dec)**: k2, p2tog, patt until 4 sts rem on LH needle, p2tog, k2.

Rep this dec on every foll **4th-4th-4th-0-0** row **2-2-2-0-0** times, then on every alt row **20-22-24-29-32** times.

After the final raglan dec, work **1** row on the rem **33-35-37-39-41** sts and leave all the sts on a spare needle **for the neck**.

### FRONT:

Using 5.0 mm needles & a ball of 2 strands of yarn together CO **82-90-98-106-114** sts.

Work in 2/2 rib as for Back until work measures 5 cm (2 in) [14 rows] total, **but** on the final row **for sizes S & XXL** inc 1 st, **for sizes M-L & XL** dec 1 st (= **83-89-97-105-115** sts).

Change to 6.0 mm needles & cont as foll:

**Next row (RS)**: **0-1-1-1-0** sts in st st, work **31-33-37-41-47** sts in Patt st, 34 sts Cable patt following the Chart & making 13 incs on the 1st row (see placement on Chart), **31-33-37-41-47** sts Patt st, **0-1-1-1-0** sts in st st. **96-102-110-118-128** sts obtained.

This row sets the patt, cont in sts as est until work measures **32-33-33-34-35 cm (12½-13-13-13¼-13¾ in) [80-82-82-84-86 rows]** total.

**Next row (RS)**: k4-4-5-5-6, work in Patt st & Cable patt as est until 4-4-5-5-6 st rem on LH needle, k4-4-5-5-6.

**Next row (WS)**: p4-4-5-5-6, work in Patt st & Cable patt as est until 4-4-5-5-6 st rem on LH needle, p4-4-5-5-6.

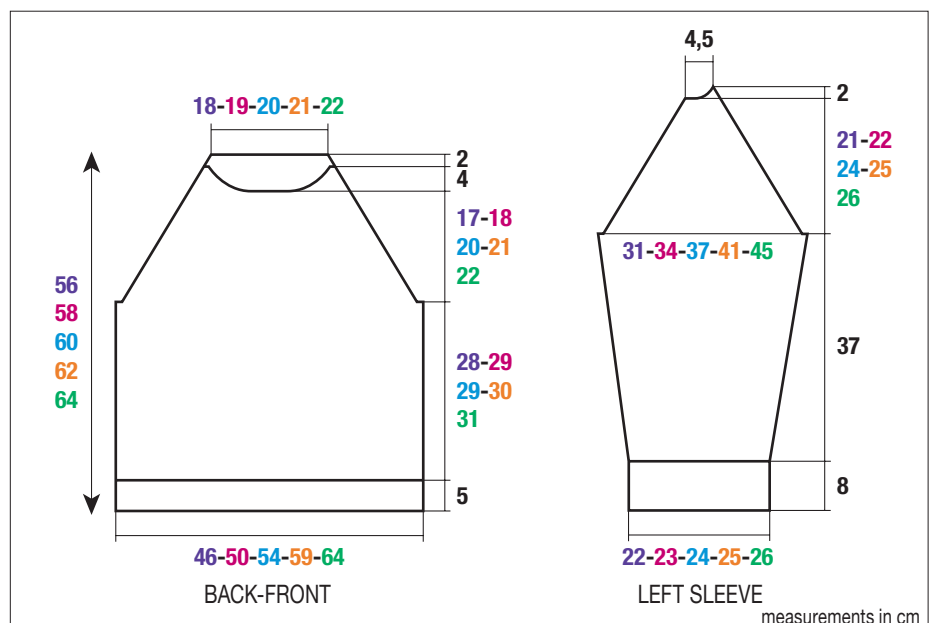

Cont in patt as est with St st at the edges and rem in Patt st & Cable patt until work measures **33-34-34-35-36** cm (**12½-13¼-13¼-13¼-14** in) [**82-84-84-86-88** rows] total.

**Raglan & neck:**

Cast off **2-2-3-3-4** sts at beg of next 2 rows. **79-85-91-99-107** sts rem.

**Next row (RS – dec):** k2, p2tog, patt until 4 sts rem on LH needle, p2tog, k2.

Rep this dec on every foll **4th-4th-4th-0-0** row **2-2-2-0-0** times, then on every alt row **18-20-22-28-31** times.

At the same time, when work measures **50-52-54-56-58** cm (**19¼-20½-21¼-22-22¼** in) [**122-128-132-136-142** rows] total, cast off the central **28-30-32-34-36** sts for the neck, each side will now be worked separately keeping raglan shaping correct and casting off at neck edge on every alt row: 3 sts once, 2 sts once, 1 st twice and the rem 4 sts.

**LEFT SLEEVE:**

Using 5.0 mm needles & a ball of 2 strands of yarn together CO **38-42-42-44-46** sts.

Work in 2/2 rib as for Back until work measures **8** cm (**3** in) [**22** rows] total, **but** on the final row **for sizes S & L** inc 3 sts, **for sizes M-XL & XXL** inc 1 st (= **41-43-45-45-47** sts).

Change to 6.0 mm needles & cont in Patt st for **10-10-8-6-6** rows.

**Next row (RS – inc):** Patt 2, inc 1, patt to last 2 sts, inc 1, patt 2.

Rep this inc on every foll **10th-10th-8th-6th-6th** row **5-2-6-11-6** more times, then on every foll **8th-8th-6th-4th-4th** row **2-6-4-2-10** times.

Cont on the **57-61-67-73-81** sts obtained until work measures **44** cm (**17¼** in) [**108** rows] total,

**Next row (RS):** k**4-4-5-5-6**, work in Patt st as est until 4-4-5-5-6 st rem on LH needle, k**4-4-5-5-6**.

**Next row (WS):** p**4-4-5-5-6**, work in Patt st as est until 4-4-5-5-6 st rem on LH needle, p**4-4-5-5-6**.

Cont in patt as est with St st at the edges and rem in Patt st until work measures **45** cm (**17¾** in) [**110** rows] total.

**Raglan:**

Cast off **2-2-3-3-4** sts at beg of next 2 rows. **53-57-61-67-77** sts rem.

Cont to work raglan dec at each end of every RS row as for Back & Front until 11 sts rem \*\*.

**Next row (WS):** Cast off 3 sts, patt to end.

**Next row (RS):** k2, p2tog, patt to end.

**Next row (WS):** Cast off 2 sts, patt to end.

**Next row (RS):** k2, p2tog, patt to end. Work 1 row straight.

Cast off rem **4** sts.

**RIGHT SLEEVE:**

Work as for Left sleeve to \*\*, work 1 row straight.

**Next row (RS):** Cast off 3 sts, patt until 4 sts, rem on LH needle, p2tog, k2. Work 1 row straight.

**Next row (RS):** Cast off 2 sts, patt until 4 sts, rem on LH needle, p2tog, k2. Work 1 row straight.

Cast off rem **4** sts.

**NECKBAND:**

Using 5 mm needles & ball of 2 strands of yarn work **6** rows in 2/2 rib, leave the sts on a spare needle.

**FINISHING:**

Join raglan seams.

Using back stitch graft the neckband around the neck, then join the short seam.

Sew sleeve & side seams.

Secure & weave in all ends.

**CABLE PATTERN**

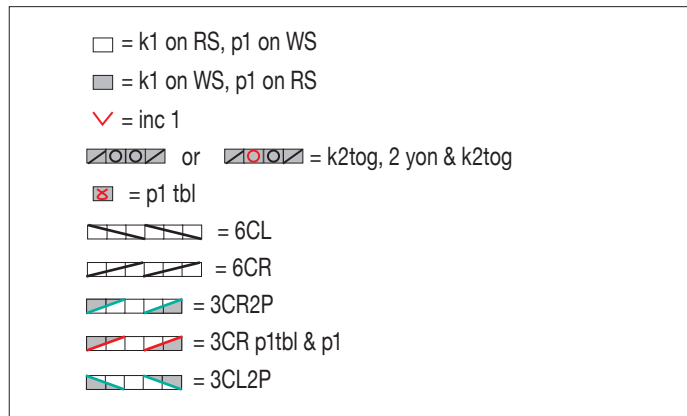
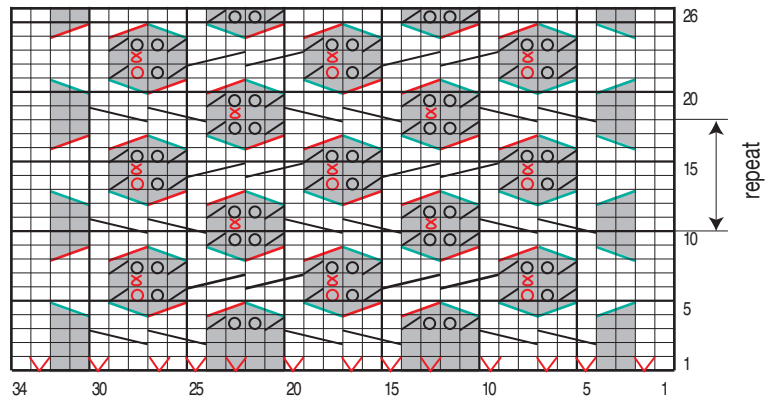

# CROCHET SLEEVELESS SWEATER



Quality:  
**LUMIS**

Crochet Hook size:  
**4.5 mm**

Sizes		4 yrs	6 yrs	8 yrs	10 yrs	12 yrs
Quality <b>LUMIS</b>		Number of bobbins				
Rouge	54765	6	7	8	9	10

### Pattern stitch:

20 sts using 4.5 mm crochet hook = 10 cm (4 in) wide.

12 rows using 4.5 mm crochet hook = 9 cm (3½ in) high.

### To make

#### BACK:

Using 4.5 mm hook make a ch of **67-73-79-85-91** sts. Work in Pattern st (= **63-69-75-81-87** sts).

When work measures **18-21-24-27-30** cm (**7-8¼-9½-10½-11¼** in) [**24-28-32-36-40** rows] total, foll diagram **no. 1** inc **10** sts at each edge over **5** rows.

Then cont on the **83-89-95-101-107** sts obtained.

#### Neck:

When work measures **31-35-39-43-47** cm (**12¼-13¾-15¼-17-18½** in) [**41-46-52-57-62** rows] total, leave the central **23-21-23-29-27** sts unworked. Then, foll diagram **no. 2** cont to work each side of the neck separately, dec at the neck edge (**29-31-33-35-37** sts remain).

#### Shoulders:

When work measures **34-38-42-46-50** cm (**13¼-15-16½-18-19¼** in) [**45-50-56-61-66** rows] total, fasten off.

#### FRONT:

Using 4.5 mm hook make a ch of **67-73-79-85-91** sts. Work in Pattern st (= **63-69-75-81-87** sts).

When work measures **18-21-24-27-30** cm (**7-8¼-9½-10½-11¼** in) [**24-28-32-36-40** rows] total, foll diagram **no. 1** inc **10** sts at each edge over **5** rows.

Then cont on the **83-89-95-101-107** sts obtained.

#### Neck:

When work measures **28-32-36-40-44** cm (**11-12½-14-15¾-17¼** in) [**37-42-48-53-58** rows] total, leave the central **19-17-19-25-23** sts unworked for the neck. Then, foll diagram **no. 3** cont to work each side of the neck separately, dec at the neck edge (**29-31-33-35-37** sts remain).

#### Shoulders:

When work measures **34-38-42-46-50** cm (**13¼-15-16½-18-19¼** in) [**45-50-56-61-66** rows] total, fasten off.

#### FINISHING

Join the shoulder seams.

Sew the side seams of the sweater (= red lines on the diagram).

### Abbreviations

Chain St = Ch

Single Crochet (UK: Double Crochet) = sc (uk: dc)

2 Double crochet together (2dc tog) (UK : 2 treble together (2tr tog)) = see 'Crochet: Stitches/Techniques'.

Double crochet (UK: Treble crochet) = dc (UK: tr)

Slip St = Sl st

### Stitches used

**PATTERN STITCH**, using 4.5 mm hook. Over an odd number of sts + 4 at the start of the 1st row.

**Row 1 (RS):** 2dc tog (uk: 2tr tog), working the 1st dc (uk: tr) in the 6th ch from the start, skip 1, work the 2nd dc (uk: tr) in the the foll st; 1 ch, \* 2dc tog (uk: 2tr tog), working the 1st dc (uk: tr) in the same st as the previous dc (uk: tr), skip 1 & work the 2nd dc (uk: tr) in the foll st, 1 ch\*, rep from \* to \*, ending the row with 1 dc (uk: tr) in the final st.

**Row 2:** 1 ch, 1 sc (uk: dc) in each of the 1st two sts, \*1 ch, 1 sc (uk: dc) in the foll space of 1 st\*, rep from \* to \*, ending with 1 ch, skip the last 2 dc tog (uk: tr tog), 1 sc (uk: dc) in each of the foll 2 sts.

**Row 3:** 4 ch, 2dc tog (uk: 2tr tog), working the 1st dc (uk: tr) in the 2nd sc (uk: dc) & the 2nd dc (uk: tr) in the foll sc (uk: dc); 1 ch, \* 2dc tog (uk: 2tr tog), working the 1st dc (uk: tr) in the same st as the previous dc (uk: tr), & the 2nd dc (uk: tr) in the foll st, 1 ch\*, rep from \* to \*, ending the row with 1 dc (uk: tr) in the final st.

Rep Rows 2 & 3.

**Crochet basics:** See 'Crochet: Stitches/Techniques'.

### Tension/Gauge

To achieve a good result it is essential to make a tension square (see "Check Your Tension" instructions at beginning of book).

#### PATTERN STITCH

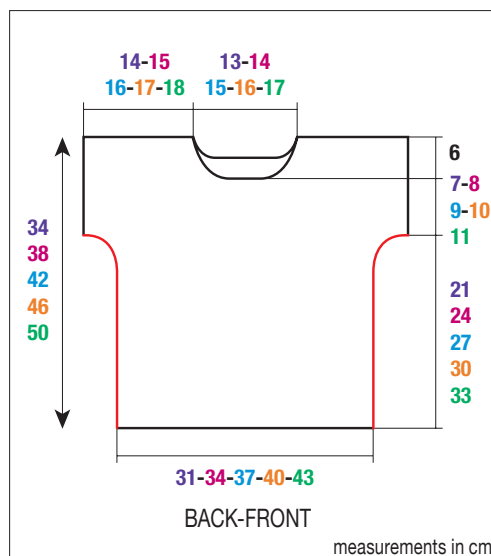
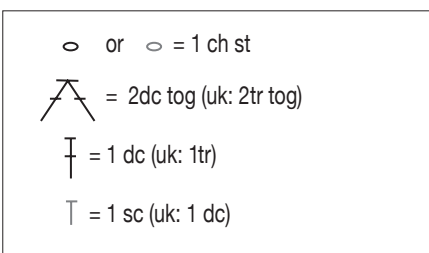
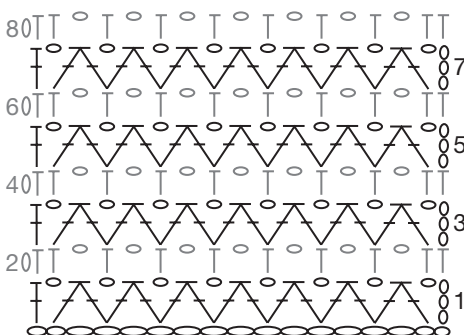

**DIAGRAM NO. 1: INCREASES**

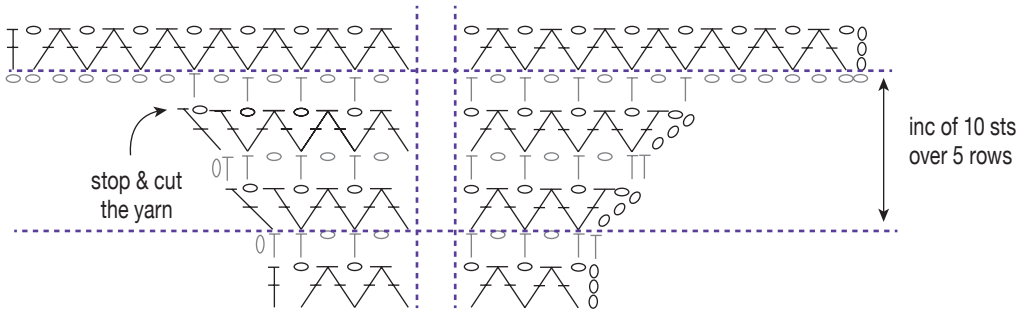

**DIAGRAM NO. 2: Back neck**

○ or ◯ = 1 ch st  
 ^ = 2dc tog (uk: 2tr tog)  
 | = 1 dc (uk: 1tr)  
 | = 1 sc (uk: 1 dc)  
 • or • = 1 sl st

**Size 4 years**

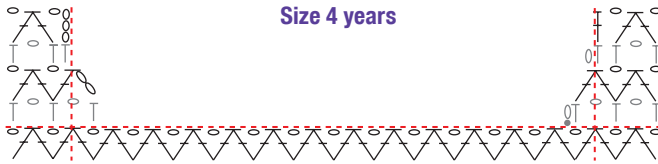

**Size 6 years**

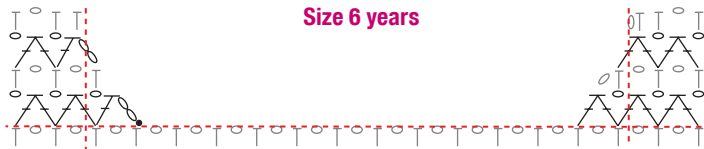

**Size 8 years**



**Size 10 years**

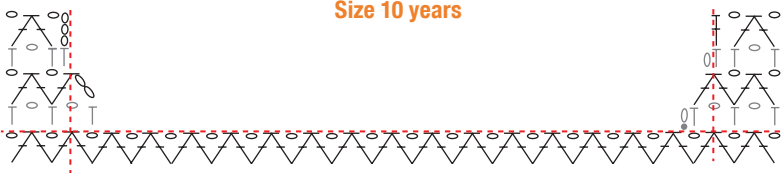

**Size 12 years**



**DIAGRAM NO. 3: Front neck**

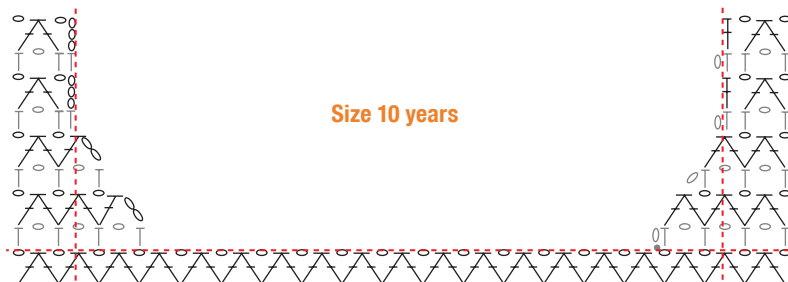
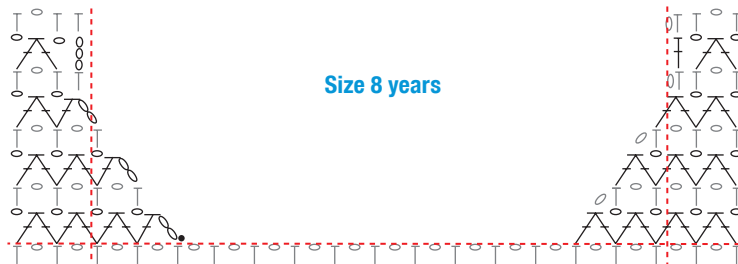
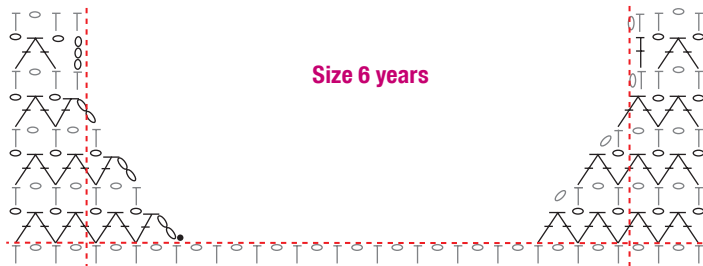
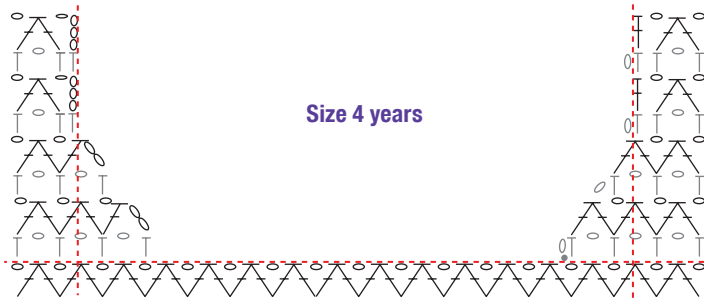

○ or ○	= 1 ch st
∧	= 2dc tog (uk: 2tr tog)
┆	= 1 dc (uk: 1tr)
┆	= 1 sc (uk: 1 dc)
• or •	= 1 sl st

# LACEWORK SWEATER



Quality:  
**LUMIS**

Needles:  
**3.5 mm**

Sizes		S	M	L	XL	XXL
Quality <b>LUMIS</b>		Number of bobbins				
Gris foncé	54760	13	14	15	17	18

## Stitches used

**GARTER ST (G.st)**, using 3.5 mm needles.

**STOCKING ST (St st)**, using 3.5 mm needles.

**LACE ST**, using 3.5 mm needles. Over a number of sts divisible by 11 (+2).

**Row 1 (RS):** p2, \*k9, p2\* rep from \*to\*.

**Row 2 & every WS row:** k2, \*p9, k2\* rep from \*to\*.

**Row 3:** p2, \*yon, sl 1, k1, pssso, k1, yon, sl 2, k1, pssso 2 sl sts, yon, k1, k2tog, yon, p2\* rep from \*to\*.

**Row 5:** p2, \*k1, yon, sl 1, k1, pssso, k3, k2tog, yon, k1, p2\* rep from \*to\*.

**Row 7:** p2, \*k2, yon, sl 1, k1, pssso, k1, k2tog, yon, k2, p2\* rep from \*to\*.

**Row 9:** p2, \*k3, yon, sl 2, k1, pssso 2 sl sts, yon, k3, p2\* rep from \*to\*.

After Row 10 rep from Row 3.

## Tension/Gauge

To achieve a good result it is essential to make a tension square (see "Check Your Tension" instructions at beginning of book).

20 sts & 30 rows over Lace St using 3.5 mm needles = 10 cm (4 in) square.

23 sts & 30 rows over St st using 3.5 mm needles = 10 cm (4 in) square.

## To make

### BACK:

CO **103-111-120-129-140** sts & work in G.st for 4 rows.

Then cont to work as foll:

**12-16-15-14-14** sts St st,

**79-79-90-101-112** sts Lace St,

**12-16-15-14-14** sts St st.

### Armholes:

When work measures **38-39-39-40-41** cm (**15-15½-15½-15¾-16¼** in) [**116-120-120-122-126** rows] total cast off 5 sts at beg of next 2 rows.

Cont on the rem **93-101-110-119-130** sts until work measures **55-57-59-61-63** cm (**21¾-22½-23¾-24-24¾** in) [**168-174-180-186-192** rows] total.

### Shoulders & Neck:

Work **4** rows G.st.

**Next row (RS):** k**22-25-29-32-37**, cast off (tightening a little) the following **49-51-52-55-56** sts for neck, then knit to end.

Leave the rem **22-25-29-32-37** sts at each edge on stitch holders for the shoulders.

### FRONT:

Work as for Back, but, for the neck, cast off the sts loosely.

### SLEEVES:

CO **61-63-65-67-69** sts & work in G.st for 4 rows.

Then cont to work as foll:

**2-3-4-5-6** sts St st,

**57** sts Lace St,

**2-3-4-5-6** sts St st.

Cont in patt as est until work measures **5** cm (**2** in) [**16** rows] total.

**Next row (RS – inc):** k2, inc 1, work to last 2 sts, inc 1, k2.

Rep this inc on every foll **12th-12th-8th-8th-8th** row **6-2-9-7-4** times, then on every foll **10th-10th-6th-6th-6th** row **2-7-4-7-11** times.

Cont on the **79-83-93-97-101** sts obtained.

### Top of sleeve:

When work measures **42** cm (**16½** in) [**128** rows] total, leave on a spare needle.

### FINISHING:

Join the shoulder seams using a chain stitch seam on the WS (see: 'Knitting: Stitches/Techniques/Tips').

Using back stitch graft the top of the sleeves into the armholes (see: 'Knitting: Stitches/Techniques/Tips').

Sew the sleeve & side seams.

Secure & weave in all ends.

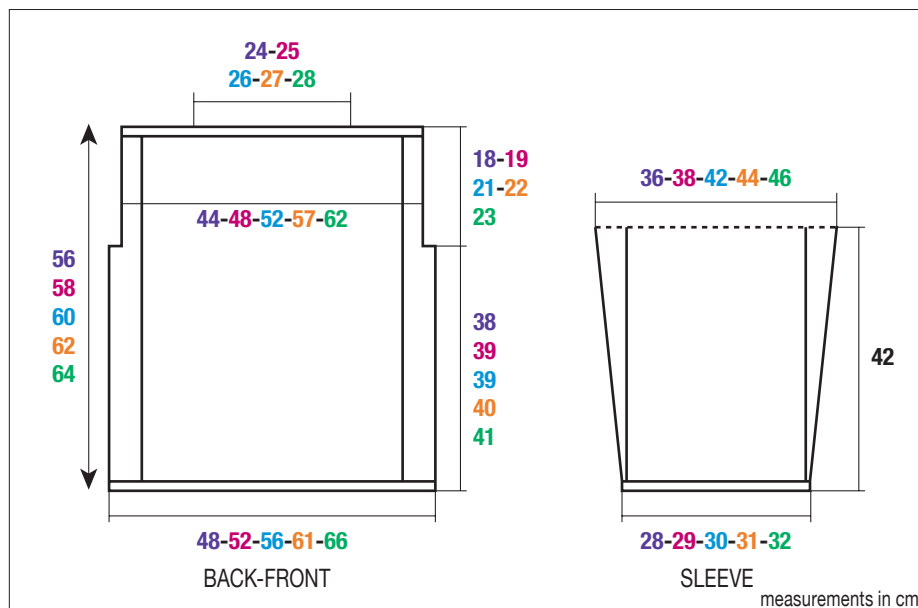

## LACE STITCH

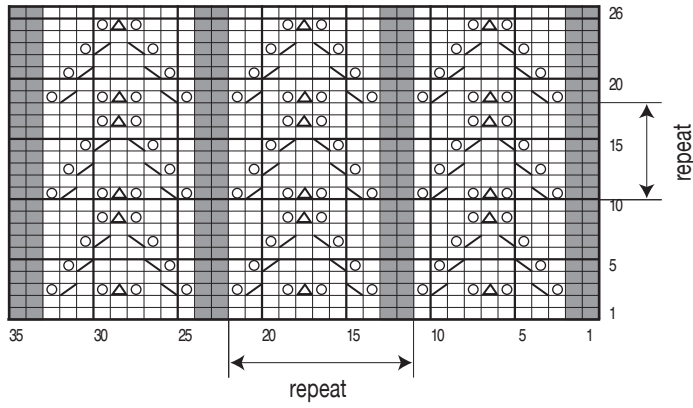

- = P on RS, K on WS
- = K on RS, P on WS
- = yon
- ▧ = sl 1, k1, pssso
- ⊗ = k2tog
- ⊠ = sl 2, k1, pssso 2 sl sts



# V NECK SWEATER



Quality:  
**LUMIS**

Needles:  
**6.5 mm**

Accessories:  
**Stitch markers ref 68395 (pk of 48)**

Sizes		S	M	L	XL	XXL
Quality LUMIS		Number of bobbins				
Gris clair	54759	8	9	10	11	13

## Stitches used

**GARTER ST (G.st)**, using 6.5 mm needles.

Knit every row.

## Tension/Gauge

To achieve a good result it is essential to make a tension square (see "Check Your Tension" instructions at beginning of book).

14 sts & 22.5 rows over G.st using 6.5 mm needles = 10 cm (4 in) square (measured with work held vertically).

## To make

### BACK:

Cast on **67-73-77-85-91** sts. Cont in G.st until work measures **39-40-40-41-42** cm (**15¼-15¾-15¾-16¼-16½** in) [**88-90-90-92-94** rows] total.

**Note**, this measurement & all future measurements should be measured with work hanging vertically.

### Armholes:

Slip a stitch marker into the first & last stitch of the next row to mark the beg of the armholes (see diagram). Cont in G.st until work measures **58-60-62-64-66** cm (**22¾-23½-24½-25-26** in) [**130-136-140-144-148** rows] total.

### Neck & Shoulders:

**Next row (RS):** Work **25-27-29-32-34** sts, cast off the central **17-19-19-21-23** sts **for the neck**, work to end.

Then, **for the shoulders**, leave the rem **25-27-29-32-34** sts at each edge on stitch holders.

### FRONT:

Cast on **67-73-77-85-91** sts. Cont in G.st until work measures **39-40-40-41-42** cm (**15¼-15¾-15¾-16¼-16½** in) [**88-90-90-92-94** rows] total.

### Armholes & Neck:

**Note**, because there is not a border around the neck edge avoid changing balls at this edge.

For the armholes: mark the first & last stitch of next row as for Back.

### For the neck:

**Next row (RS):** k **33-36-38-42-45**, cast off the central stitch **for the neck**, work to end.

**Next row (WS):** Work to cast off stitch & put rem sts on a stitch holder. Work will now be completed in 2 sections.

Work 2 rows straight on the **33-36-38-42-45** sts.

**Next row (RS- dec):** k4, k2tog, work to end.

Rep this dec on every foll 4th row **5-6-4-6-8** times, then on every foll 6th row **2-2-4-3-2** times.

### Shoulder:

Cont on the rem **25-27-29-32-34** sts until work measures **58-60-62-64-66** cm (**22¾-23½-24½-25-26** in) [**130-136-140-144-148** rows] total, then leave on a spare needle.

With WS facing pick up sts left on stitch holder & work 3 rows straight on the **33-36-38-42-45** sts.

**Next row (RS- dec):** Work to last 6 sts, sl 1, k1, pss0, k4.

Rep this dec on every foll 4th row **5-6-4-6-8** times, then on every foll 6th row **2-2-4-3-2** times.

### Shoulder:

Cont on the rem **25-27-29-32-34** sts until work measures **58-60-62-64-66** cm (**22¾-23½-24½-**

**25-26** in) [**130-136-140-144-148** rows] total, then leave on a spare needle.

### SLEEVES:

Cast on **31-32-33-34-35** sts. Work in G.st for **10-10-8-8-8** rows.

**Next row (RS – inc):** k2, inc 1, work to last 2 sts, inc 1, k2.

Rep this inc on every foll **10th-10th-8th-8th-8th** row **6-2-10-7-4** times, then on every foll **8th-8th-6th-6th-6th** row **5-10-4-8-12** times.

Cont on the **55-58-63-66-69** sts obtained until work measures **53** cm (**20¾** in) [**120** rows] total.

### Top of sleeve:

Cast off all sts.

### FINISHING:

Join the shoulder seams using a chain stitch seam on the WS (see 'Knitting: Stitches/Techniques/Tips').

Sew the top of the sleeves into the armholes between the stitch markers.

Sew sleeve & side seams.

Secure & weave in all ends.

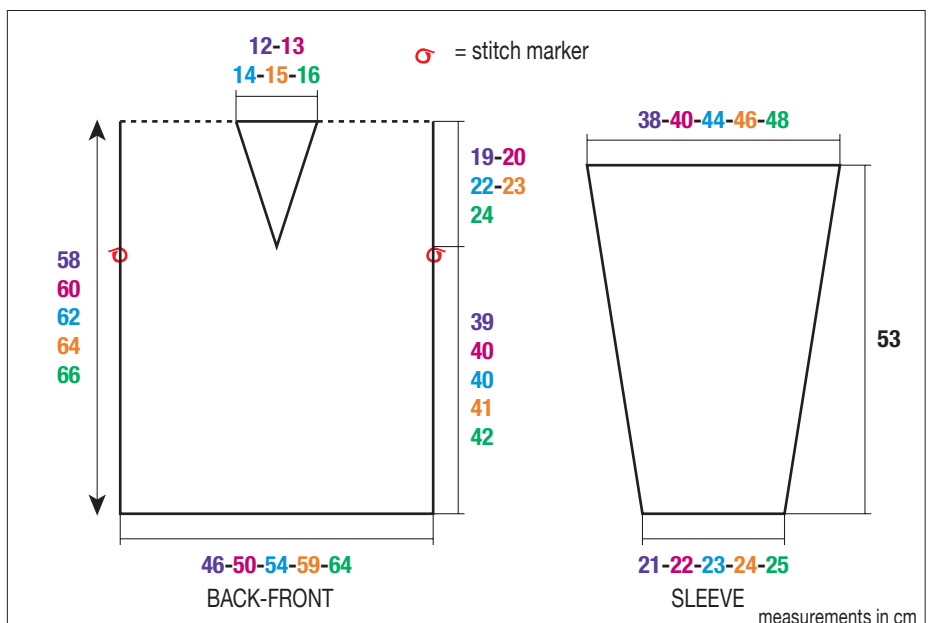

# STRIPED SWEATER



Quality:  
**LUMIS & PARADOU**

Needles:  
**3.5 & 4.0 mm**

Accessories:  
**Stitch markers ref. 68395  
(pk of 48)**

Sizes		S	M	L	XL
Quality <b>LUMIS</b>		Number of bobbins			
Noir	54771	10	11	12	13
Quality <b>PARADOU</b>		Number of balls			
Noir	43177	4	4	4	4

## Stitches used

**PATTERNED 1/1 RIB**, using LUMIS & 3.5 mm needles. Over an odd number of sts.

**Row 1 (RS):** k1tbl, \*p1, k1tbl\* rep from \*to\*.

**Row 2:** p1tbl, \*k1, p1tbl\* rep from \*to\*.

Repeat these 2 rows.

**STRIPED PATTERN ST**, using 4.0 mm needles.

**Row 1 (RS) & 2:** using PARADOU: k1tbl, \*p1, k1tbl\* rep from \*to\*.

**Row 3:** using PARADOU: knit.

**Row 4:** using PARADOU: purl.

**Row 5 & 6:** using LUMIS: purl.

**Row 7:** using LUMIS: knit.

**Row 8:** using LUMIS: purl.

**Row 9:** using LUMIS: knit.

**Row 10:** using LUMIS: purl.

**Row 11:** using LUMIS: knit.

**Row 12:** using LUMIS: purl.

After Row 12 rep from Row 1.

## Tension/Gauge

To achieve a good result it is essential to make a tension square (see "Check Your Tension" instructions at beginning of book).

22 sts & 32 rows over Striped Pattern St using 4.0 mm needles = 10 cm (4 in) square.

## To make

### BACK:

Using 3.5 mm needles & LUMIS cast on **103-111-119-129** sts.

**Row 1 (RS):** k1tbl, \*p1, k1tbl\* rep from \*to\*.

**Row 2:** p1tbl, \*k1, p1tbl\* rep from \*to\*.

These 2 rows form patterned 1/1 rib, cont as est until work measures **3 cm (1¼ in)** [**10** rows] total, **but** on the final row, **for sizes M & L** inc 1 st.

Change to 4.0 mm needles & cont in Striped Pattern St on the **103-112-120-129** sts obtained until work measures **41-42-42-43 cm (16¼-16½-16½-17 in)** [**132-134-134-138** rows] total.

### Armholes:

Slip a stitch marker into the first & last stitch of the row to mark the beg of the armholes (see diagram), then cont in Striped Pattern St until work measures **56-58-60-62 cm (22-22¾-23½-24½ in)** [**180-186-192-200** rows] total.

### Neck:

**Next row (RS):** Work **35-39-42-45** sts, cast off the central **33-34-36-39** sts for neck, work to end.

**Next row (WS):** Work to cast off sts, put rem sts on a stitch holder. Work will now be completed in 2 sections.

\*Cont to cast off at the neck edge on every alt row as foll: 3 sts once, 2 sts once. Cont on the rem **30-34-37-40** sts until work measures **58-60-62-64 cm (22¾-23½-24½-25¼ in)** [**186-192-198-206** rows] total.

### Shoulder:

Leave the rem **30-34-37-40** sts on a spare needle\*.

With WS facing pick up sts left on first stitch holder. Rep from \*to\* above.

### FRONT:

Work as for Back, marking armholes at same height, until work measures **51-53-55-57 cm (20-20¾-21¾-22½ in)** [**164-170-176-184** rows] total.

### Neck:

**Next row (RS):** Work **39-43-46-49** sts, cast off the central **25-26-28-31** sts for neck, work to end.

**Next row (WS):** Work to cast off sts, put rem sts on a stitch holder. Work will now be completed in 2 sections.

\*Cont to cast off at the neck edge on every alt row as foll: 3 sts once, 2 sts once, 1 st 4 times. Cont on the rem **30-34-37-40** sts until work measures **58-60-62-64 cm (22¾-23½-24½-25¼ in)** [**186-192-198-206** rows] total.

### Shoulder:

Leave the rem **30-34-37-40** sts on a spare needle\*.

With WS facing pick up sts left on first stitch holder. Rep from \*to\* above.

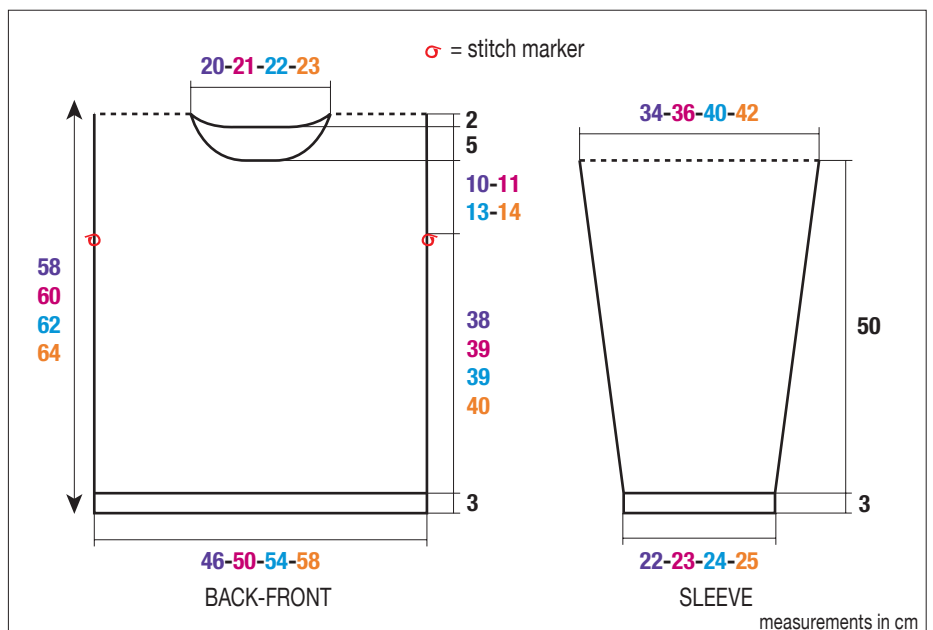

## SLEEVES:

Using 3.5 mm needles & LUMIS cast on **49-53-55-57** sts.

Work in patterned 1/1 rib as for Back until work measures **3 cm (1¼ in) [10 rows]** total, **but** on the final row, **for size S** inc 1 st; **for sizes L & XL** dec 1 st.

Change to 4.0 mm needles & cont in Striped Pattern St on the **50-53-54-56** sts obtained for **12-12-10-8** rows.

**Next row (RS – inc):** k2, inc 1, work to last 2 sts, inc 1, k2.

Rep this inc on every foll **12th-12th-10th-8th** row **8-3-2-18** times, then on every foll **10th-10th-8th-0** row **4-10-15-0** times.

Cont on the **76-81-90-94** sts obtained until work measures **53 cm (20¼ in) [170 rows]** total.

### Top of sleeve:

Leave all sts on a spare needle.

## NECKBAND:

Using 3.5 mm needles & LUMIS cast on **121-125-129-133** sts. Work 7 rows in patterned 1/1 rib then leave on a spare needle.

## FINISHING:

Join the shoulder seams using a chain stitch seam on the WS (see 'Knitting: Stitches/Techniques/Tips').

Using back stitch graft the neckband around neck edge (see 'Knitting: Stitches/Techniques/Tips'). Then join the short edges of neckband.

Using back stitch graft the sleeves into the armholes between the stitch markers.

Sew sleeve & side seams.

Secure & weave in all ends.



6

# CARDIGAN

Quality: **LUMIS & ÉCLAIR**

Needles: **6.5 mm**

Accessories:  
**4 large black lacquer shank buttons 25 mm dia. ref. 32757 (pk of 4)**  
**Stitch markers ref. 68395 (pk of 48)**

Sizes		S	M	L	XL	XXL
Quality LUMIS		Number of bobbins				
Gris foncé	54760	9	10	11	12	13
Quality ÉCLAIR		Number of balls				
Tornade	23923	8	8	9	10	11

## ● Abbreviations

**Slip 1 (sl1):** With the yarn on the WS of work, sl1 purlwise.

## ● Stitches used

The cardigan is made using 1 strand of LUMIS & 1 strand of ECLAIR throughout. Wind the balls together before use to obtain an even yarn.

**PATTERN ST**, using 6.5 mm needles. Over an odd number of sts.

**Row 1 (RS):** \*k2, yon twice\*, rep from \* to \*, ending with k3.

**Row 2:** dropping all yon's, k2, sl1, \*k1, sl1\*, rep from \* to \*, ending with k2.

**Rows 3 & 4:** k2, sl1, \*k1, sl1\*, rep from \* to \*, ending with k2.

**Row 5:** k1, \*2 yon, k2\*, rep from \* to \*.

**Row 6:** dropping all the yon's, k1, \* sl1, k1\*, rep from \* to \*.

**Rows 7 & 8:** k1, \* sl1, k1\*, rep from \* to \*.

Rep Rows 1 – 8.

**GARTER ST (G.st)**, using 6.5 mm needles.

## ● Tension/Gauge

To achieve a good result it is essential to make a tension square (see "Check Your Tension" instructions at beginning of book).

13 sts & 23 rows over Patt st using 6.5 mm needles = 10 cm (4 in) square.

## ● To make

### BACK:

Using 6.5 mm needles & a ball of 2 strands of yarn together CO **67-71-77-83-89** sts.

Cont in Patt st until work measures **32-33-33-34-35** cm (**12½-13-13-13¼-13¾** in) [**74-76-76-78-80** rows] total.

### Armholes:

Slip a stitch marker into the first and last st to mark the start of the armholes (see diagram) & cont in Pattern st until work measures **52-54-56-58-60** cm (**20½-21¼-22-22¼-23½** in) [**120-126-130-134-138** rows] total.

### Neck & shoulders:

**Next row (RS):** Cast off **8-8-9-10-10** sts, patt **18-19-21-22-24**, cast off **15-17-17-19-21** sts for the neck, patt to end.

**Next row (WS):** Cast off **8-8-9-10-10** sts, patt to cast off stitch & put rem sts on a stitch holder. Work will now be completed in 2 sections.

**\*Next row (neck edge):** Cast off 2 sts, patt to end.

**Next row (shoulder edge):** cast off **8-8-9-10-11** sts, patt to end. Work 1 row straight.

Cast off rem **8-9-10-10-11** sts\*.

With WS facing rejoin yarn to rem sts and rep from \* to \*.

### LEFT FRONT:

Using 6.5 mm needles & a ball of 2 strands of yarn together CO **27-29-32-35-38** sts.

**Next row (RS):** Work **25-27-30-33-36** sts in Patt st, k2.

**Next row:** k2, work **25-27-30-33-36** sts in Patt st.

These 2 rows set the patt, cont as est.

When work measures **2-3.5-5-5-5** cm (**¾-1¼-2-2-2** in) [**4-8-12-12-12** rows] total cont as folls:

**Next row (RS – inc):** Patt to last 2 sts, inc 1, k2.

Rep this inc on every foll **8th-8th-8th-12th-12th** row **12-12-12-1-1** more times, then on every foll **0-0-0-8th-8th** row **0-0-0-11-11** times, working the inc sts in Patt st. **40-42-45-48-51** sts.

### Armholes:

**At the same time**, when work measures **32-33-33-34-35** cm (**12½-13-13-13¼-13¾** in) [**74-76-76-78-80** rows] total, slip a stitch marker into the first and last st to mark the start of the armholes & cont in the different sts until work measures **48-50-52-54-56** cm (**18¾-19½-20½-21¼-22** in) [**110-116-120-124-128** rows] total.

**Neck:**

**Next row (RS):** Patt, until 13 sts rem on LH needle, slip these 13 sts onto a st holder, turn work and cont on rem 27-29-32-35-38 sts.

Cast off at beg of every WS row (neck edge): 2-1-1-2-3 sts 1-2-2-2-1 times, 1-2-2-1-2 sts once, 0-0-0-0-1 st 0-0-0-0-1 time. 24-25-28-30-32 sts.

**Shoulder:**

When work measures 52-54-56-58-60 cm (20½-21¼-22-22¾-23½ in) [120-126-130-134-138 rows] total, cast off for the shoulder at beg of every RS row: 8-8-9-10-10 sts 3-2-2-3-1 times, 0-9-10-0-11 sts 0-1-1-0-2 times.

**RIGHT FRONT:**

Using 6.5 mm needles & a ball of 2 strands of yarn together CO 27-29-32-35-38 sts.

**Next row (RS):** k2, work 25-27-30-33-36 sts in Patt st.

**Next row:** Work 25-27-30-33-36 sts in Patt st, k2.

Keeping the G.st border at front edge cont to work in Pattern st from the Chart, starting at the 3rd-3rd-2nd-3rd-2nd st on the Chart.

When work measures 2-3.5-5-5-5 cm (¾-1¼-2-2-2 in) [4-8-12-12-12 rows] total cont as folls:

**Next row (RS – inc):** k2, inc 1, patt to end.

Rep this inc on every foll 8th-8th-8th-12th-12th row 12-12-12-1-1 more times, then on every foll 0-0-0-8th-8th row 0-0-0-11-11 times, working the inc sts in Patt st. 40-42-45-48-51 sts.

**Armholes:**

At the same time, when work measures 32-33-33-34-35 cm (12½-13-13-13¼-13¾ in) [74-76-76-78-80 rows] total, slip a stitch marker into the first and last st to mark the start of the armholes & cont in the different sts until work measures 48-50-52-54-56 cm (18¾-19½-20½-21 ¼-22 in) [110-116-120-124-128 rows] total.

**PATTERN STITCH**

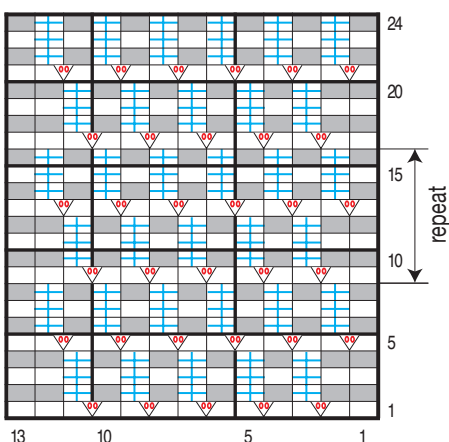

**Neck:**

**Next row (RS):** Place the first 13 sts on a st holder, rejoin yarn to rem 27-29-32-35-38 sts and patt to end.

Cont to cast off at beg of every RS row (neck edge): 2-1-1-2-3 sts 1-2-2-2-1 times, 1-2-2-1-2 sts once, 0-0-0-0-1 st 0-0-0-0-1 time. 24-25-28-30-32 sts.

**Shoulder:**

When work measures 52-54-56-58-60 cm (20½-21¼-22-22¾-23½ in) [120-126-130-134-138 rows] total, cast off for the shoulder at beg of every WS row: 8-8-9-10-10 sts 3-2-2-3-1 times, 0-9-10-0-11 sts 0-1-1-0-2 times.

**SLEEVES:**

Using 6.5 mm needles & a ball of 2 strands of yarn together CO 35-37-39-39-41 sts.

Cont in Pattern st for 12-12-10-10-10 rows.

**Next row (RS – inc):** work 2 sts, inc 1, work to last 2 sts, inc 1, work 2 sts.

Rep this inc on every foll 12th-12th-10th-10th-10th row 6-1-8-5-1 times, then on every foll 10th-10th-8th-8th-8th row 2-8-2-6-11 times.

Cont on the 53-57-61-63-67 sts obtained.

**Top of sleeve:**

When work measures 51 cm (20 in) [118 rows] total, leave the sts on a spare needle.

**FINISHING:**

Join shoulder seams.

**Neckband:**

Sl the 13 sts for the Left Front onto one 6.5 mm needle, then the 13 sts for the Right Front.

With RS facing, k13, then pick up and knit: 11-11-11-11-12 sts along the right front neck, 23-25-25-27-29 sts from the back neck, 11-11-11-11-12 sts along the left front neck, then k13 from the LH needle.

On the 71-73-73-75-79 sts obtained, work as folls: knit 2 rows, purl 3 rows, k1 row.

Cast off all the sts knitwise on the WS of work.

Using backstitch graft the top of each sleeve into armholes, between the stitch markers. See "Knitting: Stitches/Techniques/Tips".

Sew sleeve & side seams.

Sew on the buttons (see diagram for positioning).

Secure & weave in all ends.

To wear, slip the buttons between sts on the Right Front.

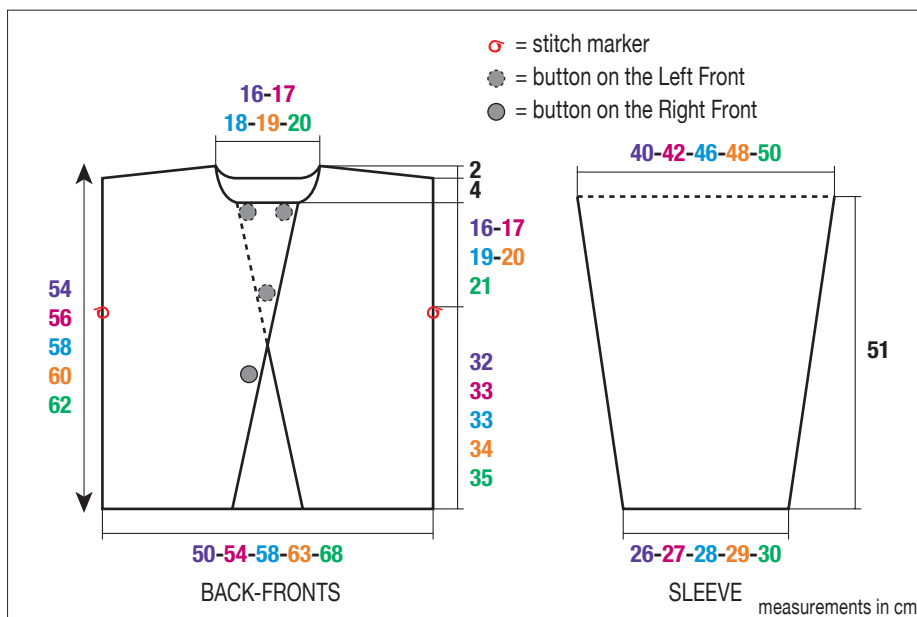

# SHORT SLEEVE CARDIGAN



Quality:  
**LUMIS & PARADOU**

Needles:  
**5.5 & 6.0 mm**

Accessories:  
**2 cream shank buttons**  
25 mm dia. ref. 42599 (pk of 6)

Sizes		4 yrs	6 yrs	8 yrs	10 yrs	12 yrs
Quality <b>LUMIS</b>		Number of bobbins				
Beige	54756	4	5	6	7	7
Quality <b>PARADOU</b>		Number of balls				
Ecru	43152	3	4	4	5	5

## ● Abbreviations

**CR** = Cross Right

**2CR**: see "Knitting: Stitches/Techniques/Tips"

## ● Stitches used

The cardigan is made using 1 strand of LUMIS & 1 strand of PARADOU together throughout. Wind the balls together before use to obtain an even yarn.

**GARTER ST (G.st)**, using 5.5 mm & 6.0 mm needles.

**STOCKING ST & REVERSE STOCKING ST (St st & Rev St st)**, using 6.0 mm needles.

**CABLE PATTERN**, using 6.0 mm needles. Over a number of sts divisible by 4 (+2).

**Row 1 (RS)**: 2CR \*p2, 2CR\* rep from \*to\*.

**Row 2**: p2, \*k2, p2\* rep from \*to\*.

Rep these 2 rows.

## ● Tension/Gauge

To achieve a good result it is essential to make a tension square (see "Check Your Tension" instructions at beginning of book).

15 sts & 18 rows over Rev St st using 6.0 mm needles = 10 cm (4 in) square.

## ● To make

### BACK:

Using 5.5 mm needles & a ball of 2 strands of yarn together CO **49-53-58-62-67** sts. Work in G.st for 4 rows.

Change to 6.0 mm needles & starting with a purl row cont in Rev St st until work measures **23-26-29-32-35** cm (**9-10¼-11½-12½-13¾** in) [**44-48-54-60-64** rows] total.

**Next row (RS)**: k **4-4-4-4-5**, p **41-45-50-54-57**, k **4-4-4-4-5**.

**Next row (WS)**: p **4-4-4-4-5**, k **41-45-50-54-57**, p **4-4-4-4-5**.

These 2 rows form Rev St st main with St st borders. Cont as est until work measures **24-27-30-33-36** cm (**9½-10½-12-13-14** in) [**46-50-56-62-66** rows] total.

### Raglan:

Cast off **2-2-2-2-3** sts at beg of next 2 rows. **45-49-54-58-61** sts rem.

Work **2-2-0-0-0** rows straight.

**Next row (RS-dec)**: k2, p2tog, work to last 4 sts, p2tog, k2.

Rep this dec on every foll RS row **11-12-14-15-16** more times.

After the final dec work 1 row on the rem **21-23-24-26-27** sts then cast off all sts for neck.

### LEFT FRONT:

Using 5.5 mm needles & a ball of 2 strands of yarn together CO **38-40-43-46-48** sts. Work in G.st for 3 rows.

**Next row (WS)**: k3, p2, \*k2, p2\* rep from \*to\* **3-3-4-4-4** more times, then k **17-19-18-21-23**.

Change to 6.0 mm needles & work **17-19-18-21-23** sts Rev St st, **18-18-22-22-22** sts Cable Pattern, 2 sts Rev St st, 1 st G.st.

Cont in pattern as est until work measures **23-26-29-32-35** cm (**9-10¼-11½-12½-13¾** in) [**44-48-54-60-64** rows] total.

**Next row (RS)**: k **4-4-4-4-5**, p **13-15-14-17-18**, **18-18-22-22-22** sts Cable Patt, p2, k1.

**Next row (WS)**: k3, **18-18-22-22-22** sts Cable Patt, k **13-15-14-17-18**, p **4-4-4-4-5**.

These 2 rows set Pattern. Cont as est until work measures **24-27-30-33-36** cm (**9½-10½-12-13-14** in) [**46-50-56-62-66** rows] total.

### Raglan & neck:

Cast off **2-2-2-2-3** sts at beg of next RS row.

Work **3-3-1-1-1** rows straight.

**Next row (RS-dec)**: k2, p2tog, work to end.

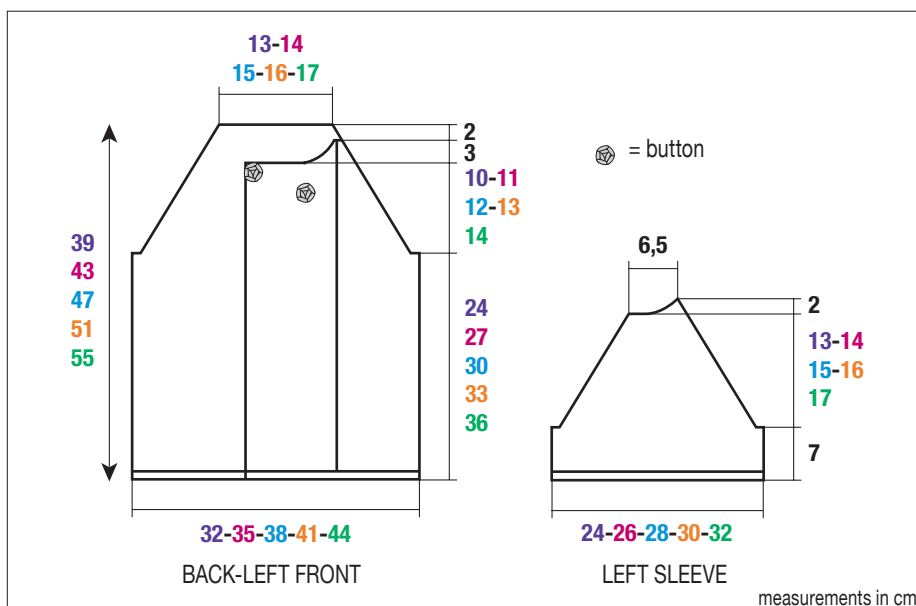

Rep this dec on every foll RS row **9-10-12-13-14** more times.

**But, at the same time**, when work measures **34-38-42-46-50** cm (**13¼-15-16½-18-19½** in) [**64-70-78-86-92** rows] total, cast off at the beg of every WS row as foll: **17-18-19-21-21** sts once, 3 sts once, 2 sts once & the rem 4 sts.

## RIGHT FRONT:

Using 5.5 mm needles & a ball of 2 strands of yarn together CO **38-40-43-46-48** sts. Work in G.st for 3 rows.

**Next row (WS):** k **17-19-18-21-23**, p2, \*k2, p2\* rep from \*to\* **3-3-4-4-4** more times, k3.

Change to 6.0 mm needles & work 1 st G.st, 2 sts Rev St st, **18-18-22-22-22** sts Cable Pattern, **17-19-18-21-23** sts Rev St st.

Cont in pattern as est until work measures **23-26-29-32-35** cm (**9-10¼-11½-12½-13¾** in) [**44-48-54-60-64** rows] total.

**Next row (RS):** k1, p2, **18-18-22-22-22** sts Cable Patt, p **13-15-14-17-18**, k **4-4-4-4-5**.

**Next row (WS):** p **4-4-4-4-5**, k **13-15-14-17-18**, **18-18-22-22-22** sts Cable Patt, k3.

These 2 rows set Pattern. Cont as est until work measures **24-27-30-33-36** cm (**9½-10½-12-13-14** in) [**46-50-56-62-66** rows] total.

### Raglan & neck:

Cast off **2-2-2-2-3** sts at beg of next WS row.

Work **2-2-0-0-0** rows straight.

**Next row (RS-dec):** Work to last 4 sts, p2tog, k2.

Rep this dec on every foll RS row **9-10-12-13-14** more times.

**But, at the same time**, when work measures **34-38-42-46-50** cm (**13¼-15-16½-18-19½** in) [**64-70-78-86-92** rows] total, cast off at the beg of every RS row as foll: **17-18-19-21-21** sts once, 3 sts once, 2 sts once & the rem 4 sts.

## LEFT SLEEVE:

\*Using 5.5 mm needles & a ball of 2 strands of yarn together CO **38-41-44-47-50** sts. Work in G.st for 4 rows.

Change to 6.0 mm needles & starting with a purl row cont in Rev St st until work measures **6** cm (**2¼** in) [**12** rows] total.

**Next row (RS):** k **4-4-4-4-5**, p **30-33-36-39-40**, k **4-4-4-4-5**.

**Next row (WS):** p **4-4-4-4-5**, k **30-33-36-39-40**, p **4-4-4-4-5**.

These 2 rows form Rev St st main with St st border. Cont as est until work measures **7** cm (**2¾** in) [**14** rows] total.

### Raglan:

Cast off **2-2-2-2-3** sts at beg of next 2 rows.

Work **2-2-0-0-0** rows straight.

**Next row (RS-dec):** k2, p2tog, work to last 4 sts, p2tog, k2.

Rep this dec on every foll RS row **9-10-12-13-14** more times. **14-15-14-15-14** sts rem.\*

**Next row (WS):** Cast off **6-7-6-7-6** sts, work to end.

**Next row (RS):** k2, p2tog, work to end. 7 sts rem.

**Next row (WS):** Cast off 2 sts, work to end.

**Next row (RS):** k2, p2tog, work to end.

**Next row (WS):** Cast off rem 4 sts.

## RIGHT SLEEVE:

Work as for Left Sleeve from \*to\*.

Work 1 row straight.

**Next row (RS):** Cast off **6-7-6-7-6** sts, work to last 4 sts, p2tog, k2. Work 1 row straight. 7 sts rem.

**Next row (RS):** Cast off 2 sts, work to last 4 sts, p2tog, k2. Work 1 row straight.

**Next row (RS):** Cast off rem 4 sts.

## FINISHING:

Join raglan seams.

### Neckband:

With RS facing, using 5.5 mm needles & a ball of 2 strands of yarn together pick up **79-83-86-90-93** sts around neck edge. Work in G.st for 4 rows then cast off all sts knitwise on the WS of work.

Sew the sleeve & side seams.

On the right front, 0.5 cm (**¼** in) from the neck, make 2 buttonholes without cutting thread (see "Knitting: Stitches/Techniques/Tips"), the 1st 6 sts from the front centre, the 2nd 12 sts later.

Sew 2 buttons onto the Left Front (see diagram for position).

Secure & weave in all ends.

### CABLE PATTERN

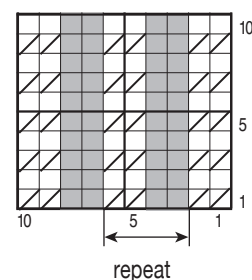

- = K on RS, P on WS
- = P on RS, K on WS
- = 2CR

# CROCHET WAISTCOAT



Quality:  
**LUMIS**

Crochet hook size:  
**3.5 mm**

Accessories:  
**8 bronze brushed metal buttons 15 mm ref. 71096 (pk of 6)**  
**60 cm black cord ref. 72622 (sold in 1 metre lengths)**  
**Black sewing thread (not sold)**

Sizes		S	M	L	XL
Quality LUMIS		Number of bobbins			
Kaki	54767	9	10	11	12

## ● Abbreviations

**Chain St = Ch**

**Slip St = Sl st**

**Double crochet (uk: treble crochet) = dc (uk: tr)**

**2dc tog (uk: 2tr tog):** See 'Crochet: Stitches/Techniques'

**3dc tog (uk: 3tr tog):** See 'Crochet: Stitches/Techniques'

## ● Stitches used

**DOUBLE CROCHET (DC) (UK: TREBLE CROCHET (TR)),** using 3.5 mm hook.

**Row 1 (RS):** 1 dc (uk: tr) into the 4th ch (= the 1st two dc (uk: tr)) then 1 dc (uk: tr) into every foll ch st.

**Row 2 & every foll row:** 3 ch (replaces the 1st dc (uk: tr)), 1 dc (uk: tr) into the 2nd dc (uk: tr), then 1 dc (uk: tr) into every foll dc (uk: tr).

## ● Tension/Gauge

To achieve a good result it is essential to make a tension square (see "Check Your Tension" instructions at beginning of book).

19 dc (uk: tr) & 11 rows over double (treble) crochet pattern using 3.5 mm crochet hook = 10 cm (4 in) square.

## ● To make

### BACK:

Make a ch of **84-92-100-108** sts. Cont in double crochet (uk: treble crochet) (= **82-90-98-106** sts).

When work measures **2 cm** ( $\frac{3}{4}$  in) [2 rows] total, cont as foll:

**Next row (RS – dec):** 3 ch (replaces the 1st dc (uk: tr)), 1 dc (uk: tr) in the 2nd dc (uk: tr), 2 dc tog (uk: 2 tr tog) over the 2 foll dc (uk: tr), work to last 4 dc (uk: tr) at the end of the row, 2 dc tog (uk: 2 tr tog) over the 2 foll dc (uk: tr), work 1 dc (uk: tr) in each of the last 2 sts.

Rep the dec row on every alt row 7 more times.

After the final dec, work **3** rows on the rem **66-74-82-90** dc (uk: tr).

**Next row (RS – inc):** 3 ch (replaces the 1st dc (uk: tr)), 1 dc (uk: tr) in the 2nd dc (uk: tr), 2 dc (uk: tr) into the next dc (uk: tr), work to last 3 dc (uk: tr) at the end of the row, 2 dc (uk: tr) into the next dc (uk: tr), work 1 dc (uk: tr) in each of the last 2 sts.

Cont on the **78-86-94-102** sts obtained until work measures **37-38-38-39** cm (**14½-15-15-15¼** in) [**41-42-42-43** rows] total.

### Armholes:

**Next row (RS):** sl1 into each of the first **6-8-8-10** sts, 3 ch (replaces the 1st dc (uk: tr)), 1 dc (uk: tr) into each of the foll **67-71-79-83** sts, leave the last **5-7-7-9** sts unworked.

Work **1** row on the rem **68-72-80-84** sts.

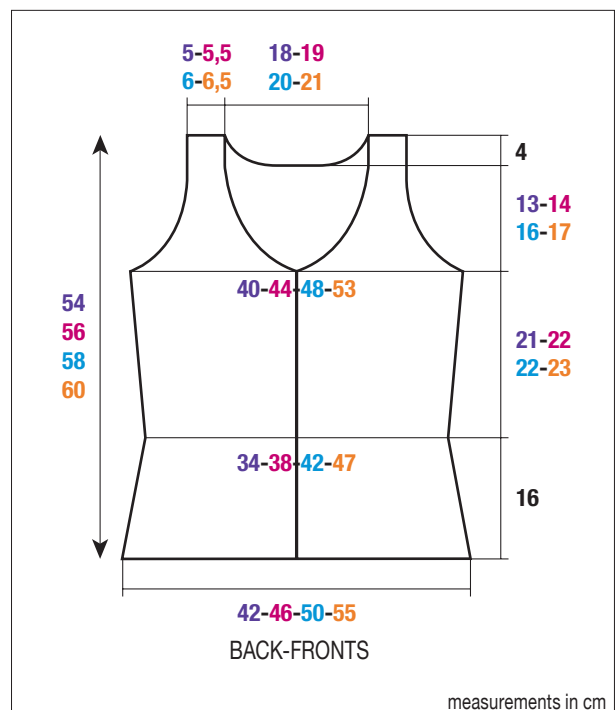
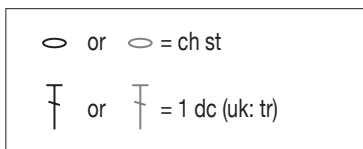
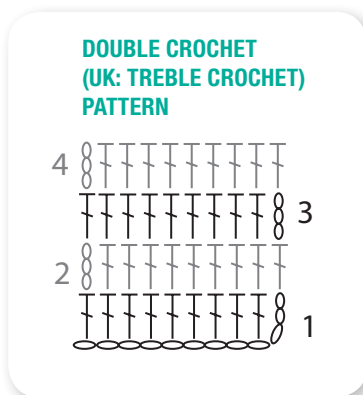

measurements in cm

**Next row (RS – dec):** 3 ch (replaces the 1st dc (uk: tr)), 1 dc (uk: tr) in the 2nd dc (uk: tr), 3 dc tog (uk: 3 tr tog) over the 3 foll dc (uk: tr), work to last 5 dc (uk: tr) at the end of the row, 3 dc tog (uk: 3 tr tog) over the 3 foll dc (uk: tr), work 1 dc (uk: tr) in each of the last 2 sts.

Cont on the rem **54-58-62-66** sts until work measures **50-52-54-56** cm (**19½-20½-21¼-22** in) [**55-57-59-62** rows] total

#### Neck:

**Next row (RS):** Work **14-15-16-17** dc (uk: tr), turn work.

**Next row (neck edge):** 3 ch (replaces the 1st dc (uk: tr)), 1 dc (uk: tr) in the 2nd dc (uk: tr), 3 dc tog (uk: 3 tr tog) over the 3 foll dc (uk: tr), work to end.

**Next row:** work to last 4 sts, 2 dc tog (uk: 2 tr tog) over the next 2 dc (uk: tr), work 2 dc (uk: tr).

**Next row:** 3 ch (replaces the 1st dc (uk: tr)), 1 dc (uk: tr) in the 2nd dc (uk: tr), 2 dc (uk: tr) into the next dc (uk: tr), work to end.

Cont on the rem **10-11-12-13** sts.

#### Shoulder:

When work measures **54-56-58-60** cm (**21¼-22-22¾-23½** in) [**59-61-63-66** rows] total, fasten off.

With RS of work facing leave the central **26-28-30-32** sts unworked for the neck and rejoin yarn to rem **14-15-16-17** sts and work to end of row.

**Next row (WS):** 3 ch (replaces the 1st dc (uk: tr)), 1 dc (uk: tr) into every st until 5 st rem, 3 dc tog (uk: 3 tr tog) over the 3 foll dc (uk: tr), 1 dc (uk: tr) into each of the last 2 sts.

**Next row:** 3 ch (replaces the 1st dc (uk: tr)), 1 dc (uk: tr) in the 2nd dc (uk: tr), 2 dc (uk: tr) into the next dc (uk: tr), work to end.

**Next row:** work to last 4 sts, 2 dc tog (uk: 2 tr tog) over the next 2 dc (uk: tr), work 2 dc (uk: tr).

Cont on the rem **10-11-12-13** sts.

#### Shoulder:

When work measures **54-56-58-60** cm (**21¼-22-22¾-23½** in) [**59-61-63-66** rows] total, fasten off.

#### LEFT FRONT:

Make a ch of **43-47-51-55** sts. Cont in double crochet (uk: treble crochet) (= **41-45-49-53** sts).

When work measures **2** cm (**¾** in) [**2** rows] total, dec at the beg (outside edge) of every RS row as for Back.

After the final dec, work **3** rows on the rem **33-37-41-45** sts.

Now inc at the beg (outside edge) of every RS row as for Back.

Cont on the **39-43-47-51** sts obtained until work measures **37-38-38-39** cm (**14½-15-15-15¼** in) [**41-42-42-43** rows] total.

#### Neck & armhole:

For the armhole dec at the beg (outside edge) of every RS row as for Back, at the same time dec 2 sts in from the neck edge at the beg of every row as foll: 3 dc tog (uk: 3 tr tog) 3 times, then 2 dc tog (uk: 2 tr tog) **11-12-11-11** times, then on every **0-0-alt-alt** row work **0-0-2-2** dc tog (uk: tr tog) **0-0-2-3** times.

Cont on the rem **10-11-12-13** sts.

#### Shoulder:

When work measures **54-56-58-60** cm (**21¼-22-22¾-23½** in) [**59-61-63-66** rows] total, fasten off.

#### RIGHT FRONT:

Make a ch of **43-47-51-55** sts. Cont in double crochet (uk: treble crochet) (= **41-45-49-53** sts).

When work measures **2** cm (**¾** in) [**2** rows] total, dec at the beg (outside edge) of every RS row as for Back.

After the final dec, work **3** rows on the rem **33-37-41-45** sts.

Now inc at the end (outside edge) of every RS row as for Back.

Cont on the **39-43-47-51** sts obtained until work measures **37-38-38-39** cm (**14½-15-15-15¼** in) [**41-42-42-43** rows] total.

#### Neck & armhole:

For the armhole dec at the end (outside edge) of every RS row as for Back, at the same time dec 2 sts in from the neck edge on every row as foll: 3 dc tog (uk: 3 tr tog) 3 times, then 2 dc tog (uk: 2 tr tog) **11-12-11-11** times, then on every **0-0-alt-alt** row work **0-0-2-2** dc tog (uk: tr tog) **0-0-2-3** times.

Cont on the rem **10-11-12-13** sts.

#### Shoulder:

When work measures **54-56-58-60** cm (**21¼-22-22¾-23½** in) [**59-61-63-66** rows] total, fasten off.

#### FINISHING

Join the shoulder seams.

Sew the side seams of the waistcoat.

Sew **4** buttons onto each front 1.5 cm (**½** in) from the edge, placing the 1st **14** cm (**5½** in) up from the base, the 2nd 5 cm (**2** in) from the neck and the others at regular intervals between these two.

#### Button fasteners (4):

Cut a 15 cm length of cord.

Fold this in half, then make a knot approx 2 cm (**¾** in) from the fold.

Make a 2nd knot around a button the Right Front.

Slip the ends of the cord to the WS & hold these in place with a few sts using the sewing thread.

# LACEWORK STOLE



Quality:  
**LUMIS & PURE DOUCEUR**

Needles  
**6.0 mm**

50 cm (19¾ in) x 200 cm (78¾ in)			
Quality LUMIS		Number of bobbins	
Beige	54756	8	
Quality PURE DOUCEUR		Number of balls	
Peau	29469	3	

## Stitches used

The stole is made using 1 strand of LUMIS & 1 strand of PURE DOUCEUR throughout. Wind balls together before use to obtain an even yarn.

**LACE STITCH**, using 6.0 mm needles. Over a number of sts divisible by 10 +1.

**Row 1 (RS):** k1, \*yon, sl 1, k1, pssso, yon, sl 1, k1, pssso, k1, k2tog, yon, k2tog, yon, k1\* rep from \*to\*.

**Row 2:** purl.

**Row 3:** k2, \*yon, sl 1, k1, pssso, yon, sl 1, k2tog, pssso, yon, k2tog, yon, k3\* rep from \*to\* ending with yon, sl 1, k1, pssso, yon, sl 1, k2tog, pssso, yon, k2tog, yon, k2.

**Row 4:** purl.

Rep rows 1-4.

## Tension/Gauge

To achieve a good result it is essential to make a tension square (see "Check Your Tension" instructions at beginning of book).

14 sts & 16 rows over Lace St using 6.0 mm needles = 10 cm (4 in) square (measured whilst holding work vertically).

## To make

Using 6.0 mm needles & a ball of 2 strands of yarn together CO **71** sts. Work in Lace St.

When work measures **200 cm (78¾ in)** [**320** rows] total cast off all sts.

Secure & weave in all ends.

### LACE STITCH

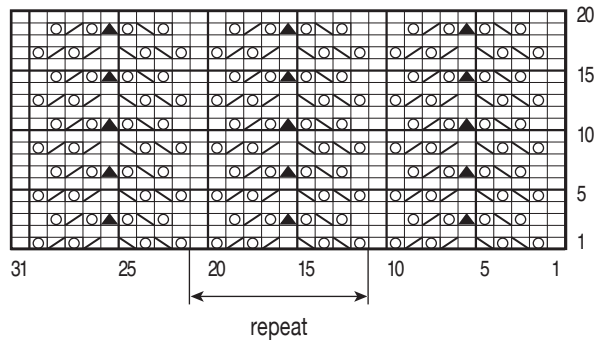

- = K1 on RS, P1 on WS
- = yon
- ⊞ = sl 1, k1, pssso
- ⊞ = k2tog
- ⊞ = sl 1, k2tog, pssso

# CROSSOVER



Quality:  
**LUMIS & REFLET**

Needles:  
**5.5 & 6.5 mm**

Accessories:  
**4 metal buttons 15 mm dia.  
ref. 32796 (pk of 4)**

Sizes		S	M	L	XL	XXL
Quality LUMIS		Number of bobbins				
Kaki	54767	8	9	10	11	11
Quality REFLET		Number of balls				
Ecru	50011	3	3	3	4	4

## Stitches used

The crossover is made using 1 strand of LUMIS & 1 strand of REFLET throughout. Wind the balls together before use to obtain an even yarn.

**MOSS ST**, using 5.5 mm & 6.5 mm needles.

**Row 1 (RS):** \*k1, p1\* rep from \*to\* ending with k1.  
Rep this row.

**REVERSE STOCKING ST (Rev St st)**, using 6.5 mm needles.

**Row 1 (RS):** purl.

**Row 2:** knit.

Rep these 2 rows.

## Tension/Gauge

To achieve a good result it is essential to make a tension square (see "Check Your Tension" instructions at beginning of book).

15 sts & 18 rows over Rev St st using 6.5 mm needles = 10 cm (4 in) square.

## To make

### BACK:

Using 5.5 mm needles & a ball of 2 strands of yarn together CO **65-71-77-85-93** sts.

**Row 1 (RS):** \*k1, p1\* rep from \*to\* ending with k1.

Cont to rep this row to form Moss St until work measures **2.5 cm (1 in)** [6 rows] total.

Change to 6.5 mm needles & starting with a purl row cont in Rev St st until work measures **34-35-35-36-37** cm (**13¼-13¾-13¾-14-14½** in) [62-64-64-66-68 rows] total.

### Armholes:

Cast off at the beg of every row as foll: **0-3-3-3-3** sts **0-2-2-2-4** times, then 2 sts **4-2-2-4-4** times. **57-61-67-71-73** sts rem.

**Next row (RS-dec):** p2, p2tog, work to last 4 sts, p2tog, p2.

Rep this dec on every foll RS row another **2-2-3-3-3** times, then cont on the rem **51-55-59-63-65** sts until work measures **51-53-55-57-59** cm (**20-20¾-22-22½-23¼** in) [92-96-100-104-108 rows] total.

### Shoulders & neck:

Cont in Rev St st, but now work the central **17-19-21-21-23** sts in Moss St, at the same time, cast off at the beg of every row as foll: **5-6-6-7-7** sts **2-4-4-4-4** times, 6 sts **2-0-0-0-0** times, then the rem **29-31-35-35-37** sts (= **6-6-7-7-7** sts at each edge for shoulder plus **17-19-21-21-23** sts for neck).

### LEFT FRONT:

**Note**, when you need to start a new ball of yarn, start at the side edge, not the angled neck edge.

Using 5.5 mm needles & a ball of 2 strands of yarn together CO **65-71-77-85-93** sts. Work in Moss St as for Back until work measures **2.5 cm (1 in)** [6 rows] total.

Change to 6.5 mm needles & work as foll:

**Next row (RS):** p **61-67-73-81-89**, 4 sts Moss St.

**Next row (WS):** 4 sts Moss St, k **61-67-73-81-89**.

These 2 rows form Rev St st with Moss St border, cont as est until work measures **6 cm (2¼ in)** [13 rows] total.

### Neckline angle & armholes:

**Next row (WS):** Cast off 4 sts, work to end.

### S:

**Next row (RS – 1 st dec):** Work until 5 sts rem on LH needle, p2tog, p3.

Rep this 1 st dec on every RS row 36 more times.

### M:

**Next row (RS – 2 st dec):** Work until 6 sts rem on LH needle, p3tog, p3.

Rep this 2 st dec on foll RS row, work 1 row straight.

**Next row (RS – 1 st dec):** Work until 5 sts rem on LH needle, p2tog, p3.

Rep this 1 st dec on every RS row 36 more times.

### L-XL & XXL:

\***Next row (RS – 1 st dec):** Work until 5 sts rem on LH needle, p2tog, p3.

Work 1 row straight.

**Next row (RS – 2 st dec):** Work until 6 sts rem on LH needle, p3tog, p3.

Work 1 row straight\*.

Rep from \*to\* **3-5-8** more times.

**Next row (RS – 1 st dec):** Work until 5 sts rem on LH needle, p2tog, p3.

Rep this 1 st dec on every RS row **32-30-26** more times.

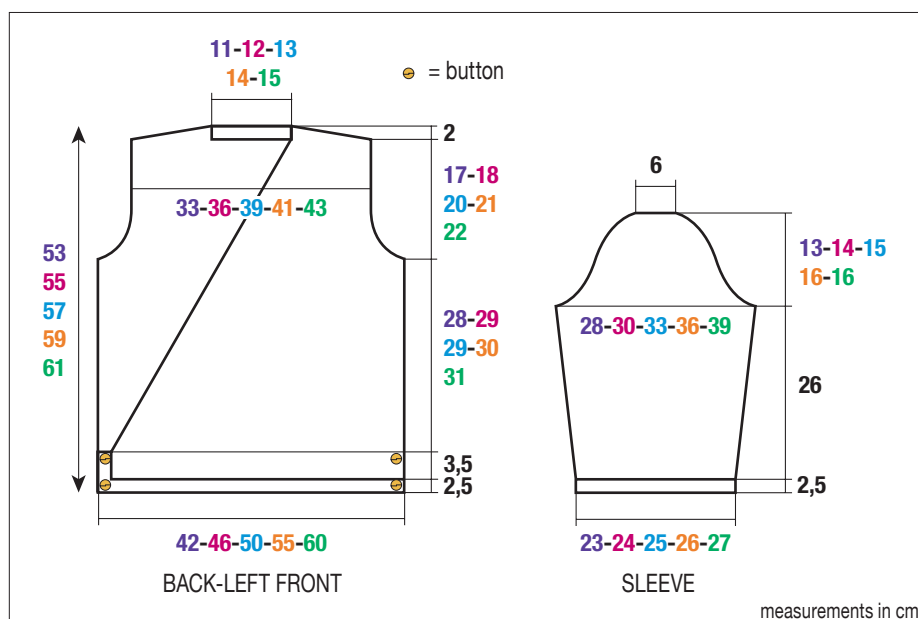

**At the same time**, when work measures **34-35-35-36-37** cm (**13¼-13¾-13¾-14-14½** in) [**62-64-64-66-68** rows] total cast off at the beg of every RS row for armholes as foll: **0-3-3-3-3** sts **0-1-1-1-2** times, 2 sts **2-1-1-2-2** times. Then dec 1 st at the beg of every RS row **3-3-4-4-4** times. (To dec 1 st at beg of row: p2, p2tog, work to end).

After the final neckline angle decrease cont on the rem **17-18-19-21-21** sts until work measures **51-53-55-57-59** cm (**20-20¾-22-22½-23¼** in) [**92-96-100-104-108** rows] total.

#### Shoulder:

Cast off at the beg of every RS row as foll: **5-6-6-7-7** sts **1-3-2-3-3** times, then **6-0-7-7-7** sts **2-0-1-3-3** times.

### RIGHT FRONT:

**Note**, when you need to start a new ball of yarn, start at the side edge, not the angled neck edge.

Using 5.5 mm needles & a ball of 2 strands of yarn together CO **65-71-77-85-93** sts. Work in Moss St as for Back until work measures **2.5** cm (**1** in) [**6** rows] total.

Change to 6.5 mm needles & work as foll:

**Next row (RS):** 4 sts Moss St, p **61-67-73-81-89**.

**Next row (WS):** k **61-67-73-81-89**, 4 sts Moss St.

These 2 rows form Rev St st with Moss St border, cont as est until work measures **6** cm (**2¼** in) [**12** rows] total.

#### Neckline angle & armholes:

**Next row (RS):** Cast off 4 sts, work to end.

#### S:

**Next row (RS – 1 st dec):** p3, p2tog, work to end. Rep this 1 st dec on every RS row 36 more times.

#### M:

**Next row (RS – 2 st dec):** p3, p3tog, work to end. Rep this 2 st dec on foll RS row, work 1 row straight.

**Next row (RS – 1 st dec):** p3, p2tog, work to end. Rep this 1 st dec on every RS row 36 more times.

#### L-XL & XXL:

\***Next row (RS – 1 st dec):** p3, p2tog, work to end.

Work 1 row straight.

**Next row (RS – 2 st dec):** p3, p3tog, work to end. Work 1 row straight\*.

Rep from \*to\* **3-5-8** more times.

**Next row (RS – 1 st dec):** p3, p2tog, work to end. Rep this 1 st dec on every RS row **32-30-26** more times.

**At the same time**, when work measures **34-35-35-36-37** cm (**13¼-13¾-13¾-14-14½** in) [**62-64-64-66-68** rows] total cast off at the beg of every WS row for armholes as foll: **0-3-3-3-3** sts **0-1-1-1-2** times, 2 sts **2-1-1-2-2** times. Then dec 1 st at the end of every RS row **3-3-4-4-4** times. (To dec 1 st at end of row: work to last 4 sts, p2tog, p2).

After the final neckline angle decrease cont on the rem **17-18-19-21-21** sts until work measures **51-53-55-57-59** cm (**20-20¾-22-22½-23¼** in) [**92-96-100-104-108** rows] total.

#### Shoulder:

Cast off at the beg of every WS row as foll: **5-6-6-7-7** sts **1-3-2-3-3** times, then **6-0-7-7-7** sts **2-0-1-3-3** times.

### SLEEVES:

Using 5.5 mm needles & a ball of 2 strands of yarn together CO **35-37-39-39-41** sts. Work in Moss St as for Back until work measures **2.5** cm (**1** in) [**6** rows] total **but** on the final row **for sizes S-XL & XXL** inc 1 st.

Change to 6.5 mm needles & starting with a purl row cont in Rev St st on the **36-37-39-40-42** sts obtained for **10-8-6-6-6** rows.

**Next row (RS – inc):** p2, inc 1, work to last 2 sts, inc 1, p2.

Rep this inc on every foll **10th-8th-6th-6th-6th** row **1-2-5-3-1** times, then on every foll **8th-6th-0-4th-4th** row **2-2-0-4-7** times.

Cont on the **44-47-51-56-60** sts obtained until work measures **28.5** cm (**11¼** in) [**52** rows] total.

#### Top of sleeve:

Cast off at the beg of every row as foll: **0-0-3-3-3** sts **0-0-2-2-4** times, 2 sts **4-4-2-4-2** times. **36-39-41-42-44** sts rem.

**Next row (RS – dec):** p2, p2tog, work to last 4 sts, p2tog, p2.

Rep this dec on every foll RS row **7-8-9-8-8** more times. **20-21-21-24-26** sts rem.

Then cast off at the beg of every row as foll: 2 sts **2-2-2-4-2** times, 3 sts **2-2-2-2-4** times, then the rem **10-11-11-10-10** sts.

### FINISHING:

Join shoulder seams.

Sew the top of each sleeve into armholes.

Sew sleeve & side seams.

Sew the buttons onto the left front (see diagram for positioning).

Secure & weave in all ends.

To wear, slip the buttons between sts on the right front.



# CROCHET PURSE



Quality: **LUMIS**

Crochet hook size: **3.5 mm**



Accessories:

**White perforated vinyl canvas 45 x 25 cm (17 3/4 x 10 in) ref. 70829**

**Beige sewing thread (not sold)**

**1 silver magnetic button 19 mm ref. 41240 (pk of 3)**

**1 plum glass stone ref. 30839**

**25 cm (10 in) wide x 16 cm (6 1/4 in) high**

Quality LUMIS	Number of bobbins	
Beige 54756	3	

**Crochet basics:** See 'Crochet: Stitches/Techniques'.

**Embroidery stitches:** See 'Embroidery: Stitches'.

When work measures **40 cm (15 3/4 in) [108 rows]** total, fasten off.

## FINISHING

Cut a rectangle of white vinyl to measure 45 x 25 cm (17 3/4 x 10 in). Then, on the last 19 lines of holes, using LUMIS embroider in back stitch follow the Chart.

### Following the diagram:

Place the WS of the vinyl against the WS of the crochet piece. Then, with the sewing thread join the 2 pieces using back stitch 0.5 cm (1/4 in) in from the edges (= red dots).

Fold the bottom of the purse up to the coloured yarn and join the sides by working 1 row of sl st in LUMIS (= white dots).

With the sewing thread, sew on the magnetic button, then the glass stone.

## ● Abbreviations

**Chain St** = Ch

**Single Crochet (uk: Double Crochet)** = sc (uk: dc)

**Slip St** = Sl st

## ● Stitches used

**SINGLE CROCHET (SC) (UK: DOUBLE CROCHET (DC))**, using 3.5 mm hook.

**Row 1 (RS):** 1 sc (uk: dc) into the 2nd ch & each foll ch.

**Row 2 & every foll row:** 1 ch, 1 sc (uk: dc) into the 1st sc & every foll sc (uk: dc).

## ● Tension/Gauge

To achieve a good result it is essential to make a tension square (see "Check Your Tension" instructions at beginning of book).

20 sc (uk: dc) & 27 rows over sc (uk: dc) using 3.5 mm crochet hook = 10 cm (4 in) square.

## ● To make

The purse measures approx. 25 cm (10 in) wide & 16 cm (6 1/4 in) high.

Using 3.5 mm hook make a ch of 51 sts. Work in sc (uk: dc) (= 50 sc (uk: dc)).

When work measures **31 cm (12 1/4 in) [84 rows]** total, slip a different coloured piece of yarn in the 1st and last st to mark the start of the flap & cont in sc (uk: dc).

## CHART

24.5 cm (9 1/2 in) = 61 holes

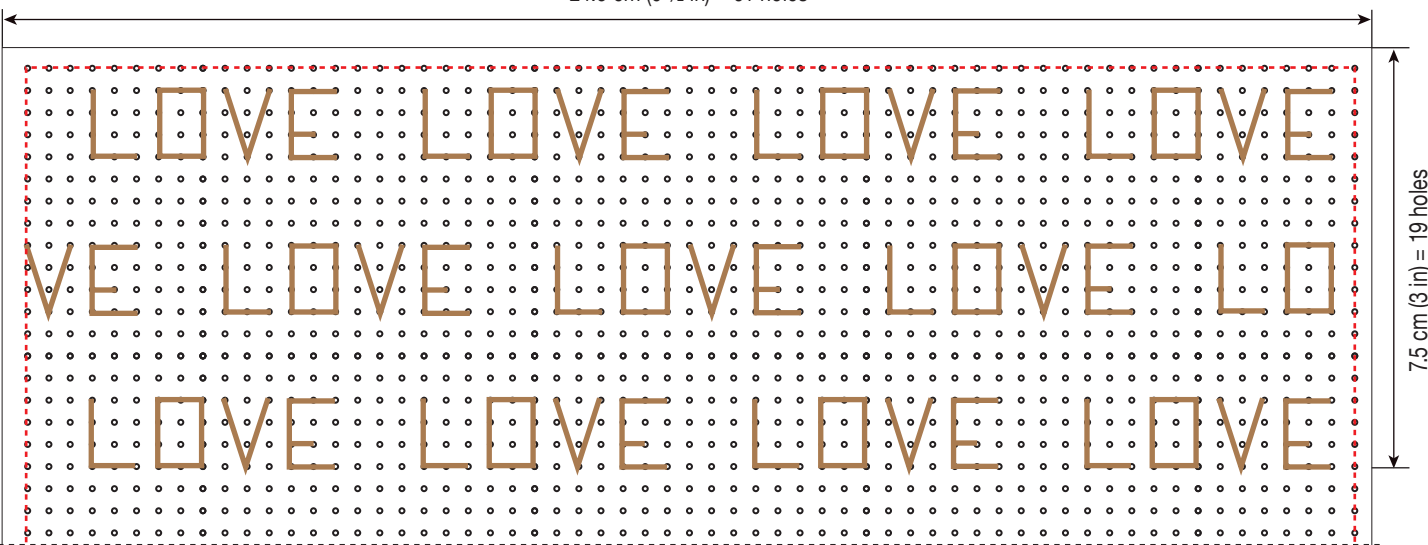

— = back stitch in LUMIS

